



Stone Veneer
Hardscapes



Sheds
Garages
Buildings
Outdoor Furniture





Let's create your masterpiece!

- 5 Green Mountain Veneer
- 23 Landscaping Stone
- 44 Bulk Landscaping Materials
- 47 Accessory Dwelling Units
- 68 Accessory Buildings
- 72 Garages
- 84 Storage Buildings
- 114 Animal Structures
- 122 Gazebos, Pergolas, Pavilions
- 128 Play Sets
- 133 Outdoor Furniture



Meet The Team



Dave
Founder and Owner



David
Sales Manager

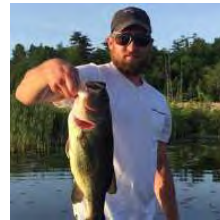

Tyler
Shed Captain



Tina
Office Manager



Alysia
Jill of All Trades



Chris
Ultimate Utility Player

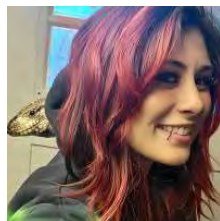

Jenn (aka DJ)
Idea Alchemist



Heidi
Inventory Control and
Transportation Specialist



Jenn
Website and
Marketing Manager



Ren
Transportation
Expert



Britney
Distribution
Connoisseur

What We Do

Our friendly team of professionals will help you develop ideas, execute visions and create masterpieces.

We are committed to maintaining the highest standards of excellence across each of our premium product lines.

Local and nationwide shipping is offered for any of our products.

We provide seamless delivery, precision installation, and expert site preparation for your custom-built outdoor structure.



Green Mountain Veneer

Natural Stone Veneer Specifications and Style Guide

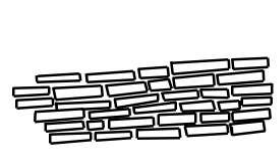
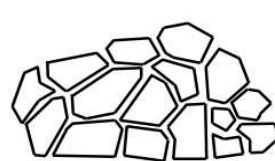
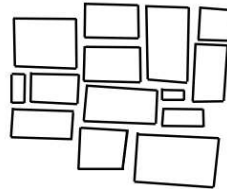
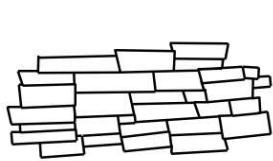

SAWN BACK THIN VENEER	ASHLAR This stone provides a linear look with long, fairly rectangular shapes. It exhibits the face of the stone, revealing striations that can be very colorful.	SQUARES & RECTANGLES These natural seam faced pieces are guillotined and formed into rough squares and rectangles.	MOSAIC Irregular shaped quarry material exhibiting the seam and/or the natural face of the stone. No shape is the same size or cut, making each project unique.	LEDGE This roughly rectangular shaped cut has a linear appearance with a shallow, slightly varied height. Split faced stones dominate this cut, but the seams are also seen.
Thickness	3/4" to 1 1/2"	3/4" to 1 1/2"	3/4" to 1 1/2"	3/4" to 1 1/2"
Height	4"+/- to 12"+/-	n/a	n/a	1"+/- to 5"+/-
Length	6"+/- to 20"+/-	n/a	n/a	6"+/- to 12"+/-
Facing Area	n/a	1/4 sqft to 1 1/4 sqft+/-	1/4 sqft to 1 1/4 sqft+/-	n/a
Corner Returns	3" return minimum	3" return minimum	3" return minimum	3" return minimum
Weight	up to 15 lbs per sq ft	up to 15 lbs per sq ft	up to 15 lbs per sq ft	up to 15 lbs per sq ft

FULL BED BUILDING STONE	ASHLAR	SQUARES & RECTANGLES	MOSAIC	LEDGE
Thickness	3" to 6"	3" to 6"	3" to 6"	3" to 6"
Height	4"+/- to 12"+/-	n/a	n/a	3"+/- to 6"+/-
Length	6"+/- to 20"+/-	n/a	n/a	8"+/- to 12"+/-
Facing Area	n/a	1/4 sqft to 3 sqft+/-	1/4 sqft to 3sqft+/-	n/a
Coverage	35 - 40 sqft per ton	35 - 40 sqft per ton	35 - 40 sqft per ton	35 - 40 sqft per ton



View our
INSTALLATION
video series on
YouTube



Nationwide
delivery
available





Squares & Rectangles

American Granite

A medium to coarse grained granite offering a rugged look. The weathered faces display earth tones including browns, tans, blues and rust orange while the split faces offer a mix of blue, burgundy, pink, green, brown, black and white.

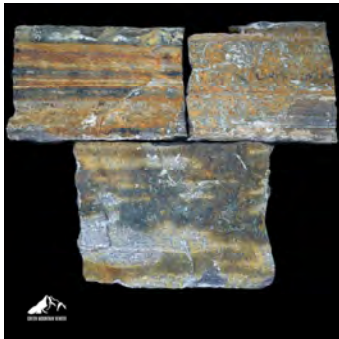

Ashlar
 Flats \$26.10/sq ft
 Corners \$29.65/lin ft
 Full Bed \$786/ton

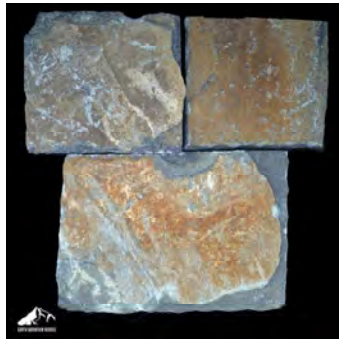

Squares & Rectangles
 Flats \$26.10/sq ft
 Corners \$29.65/lin ft
 Full Bed \$786/ton



Mosaic
 Flats \$26.10/sq ft
 Corners \$29.65/lin ft
 Full Bed \$636/ton



Ledge
 Flats \$26.10/sq ft
 Corners \$29.65/lin ft
 Full Bed \$786/ton

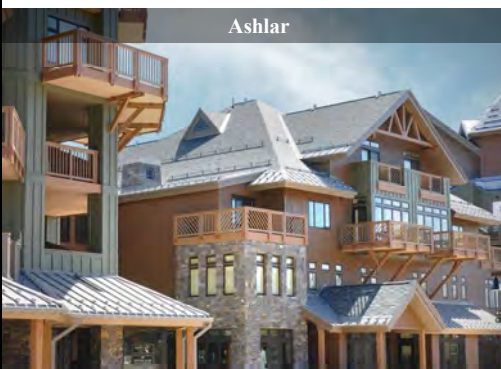

Ashlar

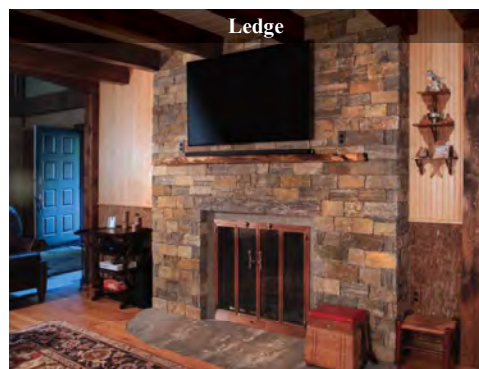

Ledge

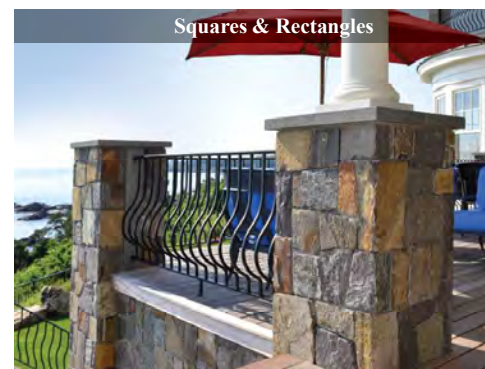

Squares & Rectangles



Squares & Rectangles

Corinthian Granite

Blue is the dominating tone of this medium to coarse grained granite with a mixture of green, pink, brown, burgundy and white. Some pieces will feature black speckles consisting of red and black garnet inclusions and quartz crystals.



Ashlar

Flats \$19.05/sq ft
Corners \$22.60/lin ft
Full Bed \$615/ton



Squares & Rectangles

Flats \$19.05/sq ft
Corners \$22.60/lin ft
Full Bed \$615/ton



Mosaic

Flats \$19.05/sq ft
Corners \$22.60/lin ft
Full Bed \$590/ton



Ledge

Flats \$19.05/sq ft
Corners \$22.60/lin ft
Full Bed \$615/ton

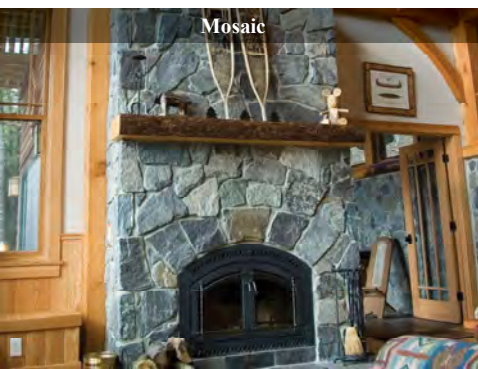

Mosaic

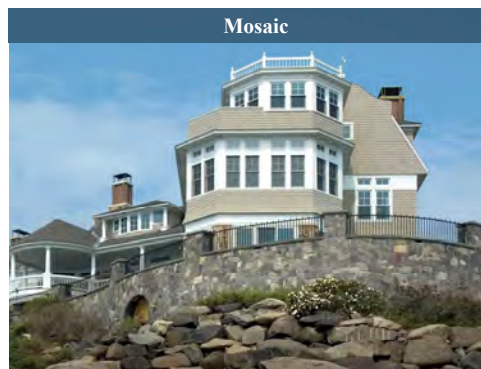

Mosaic



Ashlar



Ledge and Ashlar Blend

Dove Cove

This beautiful blend features granites and fieldstones from Vermont and New Hampshire. The diverse color pallet includes a range from white, grey and green to tan, brown, and copper.



Ashlar
Flats \$17.25/sq ft
Corners \$28.50/lin ft



Squares & Rectangles
Flats \$16.65/sq ft
Corners \$23.75/lin ft

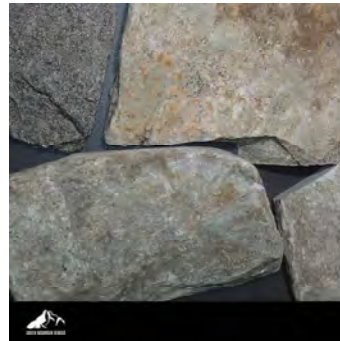

Mosaic
Flats \$15.60/sq ft
Corners \$23.75/lin ft



Ledge
Flats \$17.25/sq ft
Corners \$27.30/lin ft



Mixed Cuts

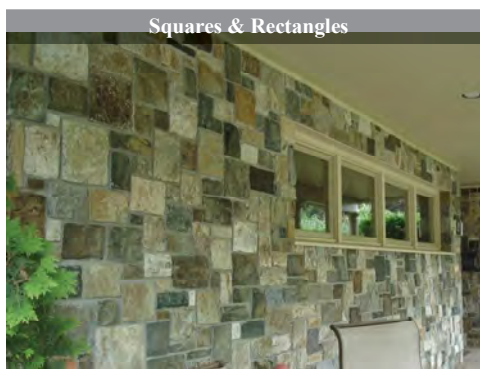

Squares & Rectangles



Mosaic



Farmhouse Blend

A naturally varied palette of warm tans and soft browns is complemented by cooler gray undertones, creating a balanced and inviting color range. Subtle shifts between sandy beige, weathered taupe, and muted charcoal add depth and texture, giving each installation a richly layered, organic appearance.



Ashlar

Flats \$16.10/sq ft
Corners \$24.95/lin ft

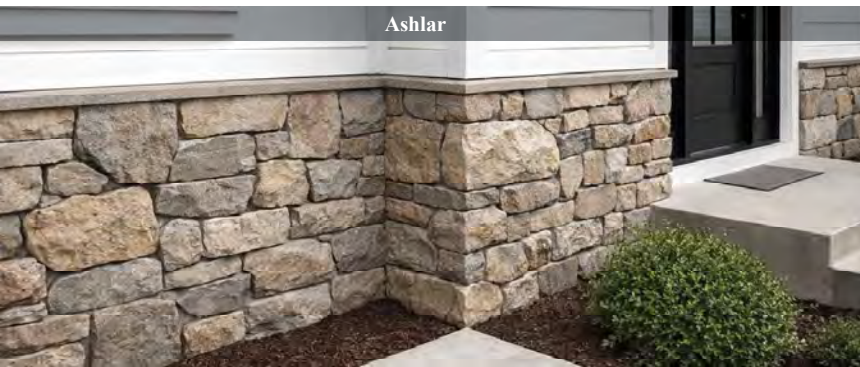



Mosaic

Native Fieldstone

These natural rounded stones are hand selected from New England fields, woods and mountainsides. With rich textures and unique shapes these stones present an assortment of soothing earth tones.



Mosaic



Mosaic

Flats \$15.20/sq ft
Corners \$23.75/lin ft



Mosaic



Mosaic



Old Chester Granite

Layered, deeper grays enriched with high mica content produce a refined, silvery luster. Subtle hints of green and muted gold emerge throughout, offering nuanced color variation and a distinctly natural elegance.



Ashlar
 Flats \$15.10/sq ft
 Corners \$20.60/lin ft
 Full Bed \$615/ton



Squares & Rectangles
 Flats \$15.10/sq ft
 Corners \$20.60/lin ft
 Full Bed \$615/ton



Mosaic
 Flats \$15.10/sq ft
 Corners \$20.60/lin ft
 Full Bed \$500/ton



Ledge
 Flats \$15.10/sq ft
 Corners \$20.60/lin ft



Ledge

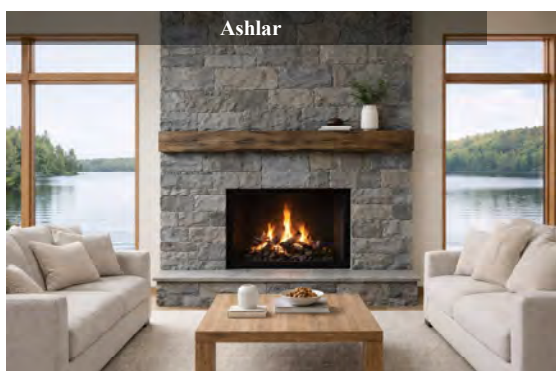

Ashlar



Squares & Rectangles



Squares & Rectangles

Panton Pummel

Quarried along Lake Champlain, this stone ranges from light to dark gray with subtle tan weathering throughout. As a natural sedimentary material, it often features embedded fossils that enhance its texture and visual character.



Squares & Rectangles

Flats \$16.65/sq ft
Corners \$22.60/lin ft



Mosaic

Flats \$16.35/sq ft
Corners \$22.60/lin ft



Ledge

Flats \$16.65/sq ft
Corners \$24.95/lin ft



Ashlar



Ledge



Quaker Hill Grey Blend

Deep gray tones come alive ranging from light to dark hues. Gentle infusions of warm tans and browns create movement and richness, making each installation feel both grounded and elevated.



Ashlar

Flats \$16.05/sq ft
 Corners \$22.05/lin ft
 Full Bed \$615/ton



Squares & Rectangles

Flats \$16.05/sq ft
 Corners \$22.05/lin ft
 Full Bed \$615/ton



Mosaic

Flats \$16.05/sq ft
 Corners \$22.05/lin ft
 Full Bed \$500/ton

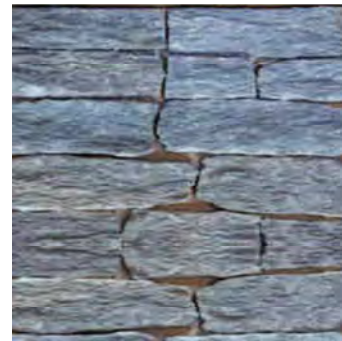

Ledge

Flats \$16.05/sq ft
 Corners \$22.05/lin ft



Miced Cuts



Squares & Rectangles



Mosaic



Ashlar and Squares & Rectangles

Raven Hill Blend

Featuring a dominant range of deep gray to near-black tones, this veneer highlights the natural density and richness of the stone. The charcoal palette is enhanced by subtle variations in shade, giving the surface a dynamic yet cohesive appearance.



Ashlar
 Flats \$15.25/sq ft
 Corners \$20.60/lin ft
 Full Bed \$615/ton



Squares & Rectangles
 Flats \$15.25/sq ft
 Corners \$20.60/lin ft
 Full Bed \$615/ton



Mosaic
 Flats \$15.25/sq ft
 Corners \$20.60/lin ft
 Full Bed \$500/ton



Ledge
 Flats \$15.25/sq ft
 Corners \$20.60/lin ft

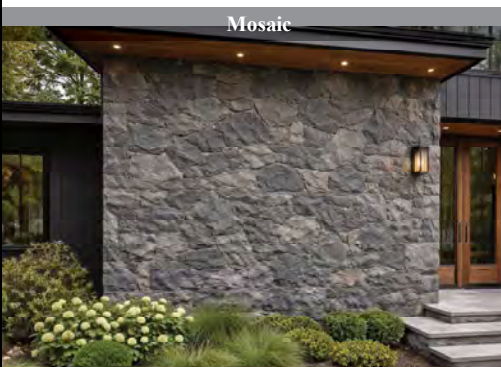

Mosaic



A diverse array of stones in various cuts and styles, paired with a knowledgeable and friendly staff. They make every aspect of your stone project easy and also offer a range of other hardscape materials. Excellent products and outstanding professional service. Highly recommended.

ERIC D. ~ BURLINGTON, VT



Ashlar



Ledge

Saratoga Granite

A dynamic blend of warm brown earth tones and layered blue hues defines this medium to coarse grained granite. Supporting notes of tan and rust orange add subtle warmth, while darker mineral accents bring depth and dimension throughout. Natural quartz crystals and garnet inclusions provide texture and interest.



Ashlar

Flats \$19.05/sq ft
Corners \$22.60/lin ft
Full Bed \$615/ton

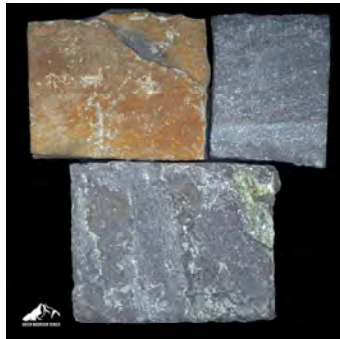

Squares & Rectangles

Flats \$19.05/sq ft
Corners \$22.60/lin ft
Full Bed \$615/ton



Mosaic

Flats \$19.05/sq ft
Corners \$22.60/lin ft
Full Bed \$585/ton



Ledge

Flats \$19.05/sq ft
Corners \$22.60/lin ft
Full Bed \$615/ton

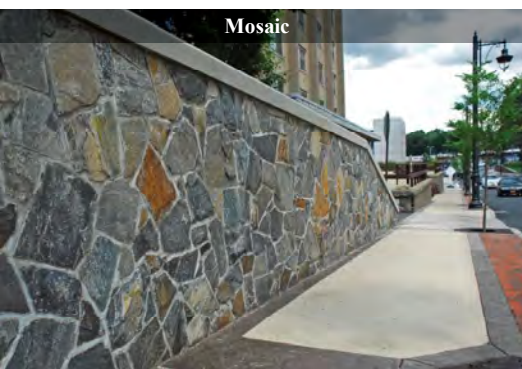

Mosaic



Ashlar and Squares & Rectangles Blend



Squares & Rectangles



South Bay Quartzite

This quartzitic sandstone presents a refined, smooth appearance complemented by rich natural texture. Its color palette blends tan, antique white, ice blue, amber, and brown tones, creating a balanced and visually dynamic finished result.

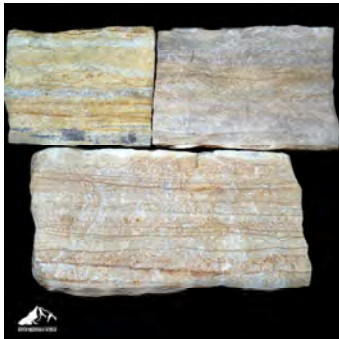

Ashlar
 Flats \$20.20/sq ft
 Corners \$22.60/lin ft
 Full Bed \$625/ton



Squares & Rectangles
 Flats \$20.20/sq ft
 Corners \$22.60/lin ft
 Full Bed \$625/ton

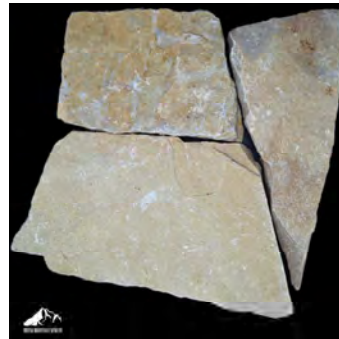

Mosaic
 Flats \$20.20/sq ft
 Corners \$22.60/lin ft
 Full Bed \$585/ton



Ledge
 Flats \$20.20/sq ft
 Corners \$22.60/lin ft
 Full Bed \$625/ton

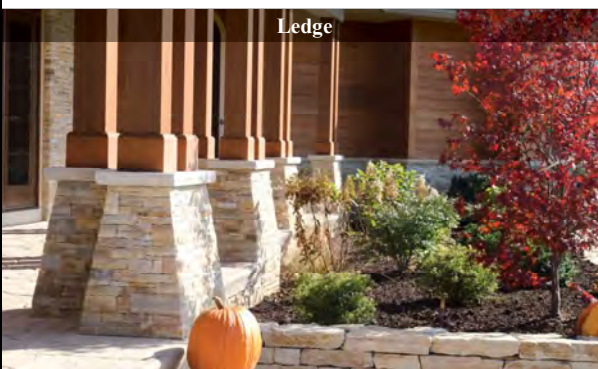

Ledge



Ashlar

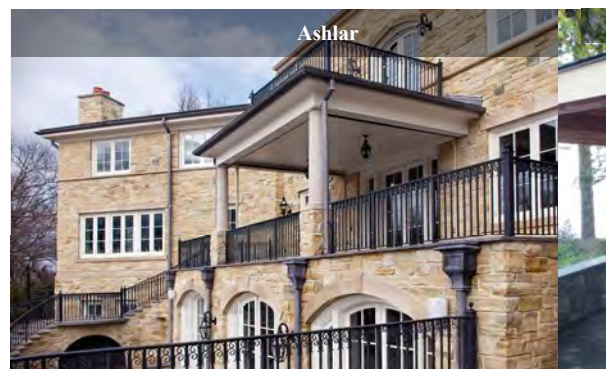

Ashlar



Squares & Rectangles

Ticonderoga Granite

This is a colorful blend of fine grained granites featuring a watercolor-like palette of gray-blue, caramel, pink, lilac, amber, pale green and deep shades of brown.



Ashlar

Flats \$19.05/sq ft
Corners \$22.60/lin ft
Full Bed \$650/ton



Squares & Rectangles

Flats \$19.05/sq ft
Corners \$22.60/lin ft
Full Bed \$650/ton



Mosaic

Flats \$19.05/sq ft
Corners \$22.60/lin ft
Full Bed \$600/ton



Ledge

Flats \$19.05/sq ft
Corners \$22.60/lin ft
Full Bed \$655/ton



Squares & Rectangles



Mosaic



Ashlar and Ledge Blend



Squares & Rectangles

Vermont Ash Gray Mica

This Vermont quarried stone is a metamorphic rock consisting of mica schist, granite and quartz. Mostly charcoal gray, it features a black to blue color with the occasional touch of tan.



Ashlar

Flats \$15.90/sq ft
Corners \$23.15/lin ft



Squares & Rectangles

Flats \$15.75/sq ft
Corners \$21.95/lin ft



Mosaic

Flats \$14.60/sq ft
Corners \$21.95/lin ft



Mosaic



Ashlar

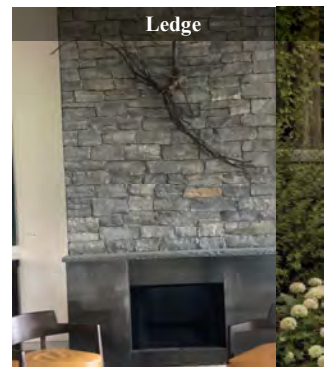

Ledge



Ledge, Ashlar and Squares & Rectangle blend

Vermont Blend

A balanced mix of cool grays and warm earth tones defines Vermont Blend, with shades ranging from soft blue-gray and charcoal to sandy tan and muted rust. Natural variation between the cooler and warmer hues creates depth and movement.



Ashlar

Flats \$15.25/sq ft
Corners \$20.60/lin ft
Full Bed \$615/ton



Squares & Rectangles

Flats \$15.25/sq ft
Corners \$20.60/lin ft
Full Bed \$615/ton



Mosaic

Flats \$15.25/sq ft
Corners \$20.60/lin ft
Full Bed \$500/ton



Ledge

Flats \$15.25/sq ft
Corners \$20.60/lin ft

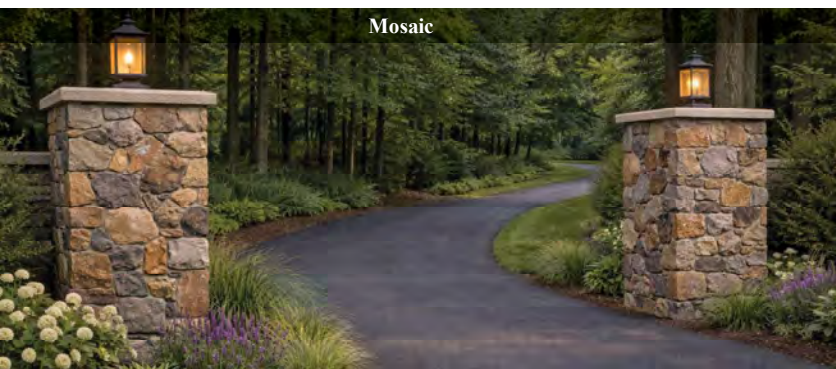

Mosaic

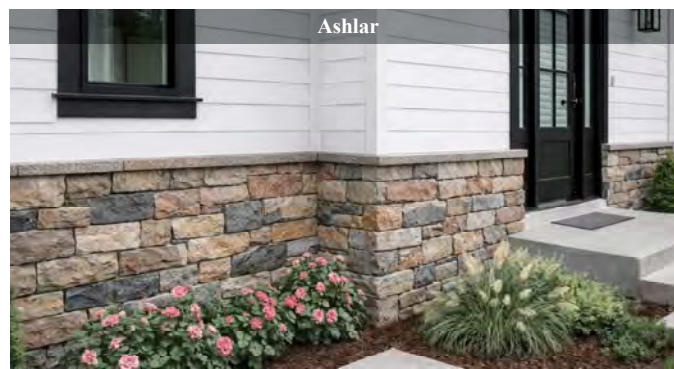

Ashlar



Ashlar

Vermont Verde Mica

Quarried in Vermont, this exceptionally unique colored stone has a dark gray tone with dark green undertones.



Ashlar
Flats \$15.90/sq ft
Corners \$23.15/lin ft



Squares & Rectangles
Flats \$15.50/sq ft
Corners \$21.95/lin ft



Mosaic
Flats \$14.60/sq ft
Corners \$21.95/lin ft

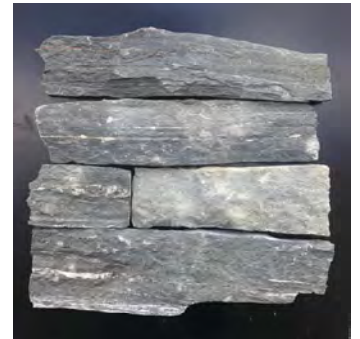

Ledge
Flats \$15.90/sq ft
Corners \$23.15/lin ft



Squares & Rectangles



Ashlar



Ashlar



Vermont Weathered Mica

This Vermont granite and mica schist stone features natural brown tones with rustic tans and a touch of dark gray and blue.

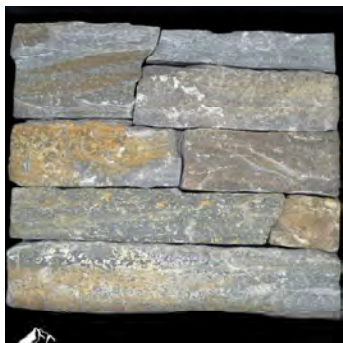

Ashlar
Flats \$15.90/sq ft
Corners \$23.15/lin ft



Squares & Rectangles
Flats \$15.50/sq ft
Corners \$21.95/lin ft



Mosaic
Flats \$14.60/sq ft
Corners \$21.95/lin ft



Squares & Rectangles



Squares & Rectangles

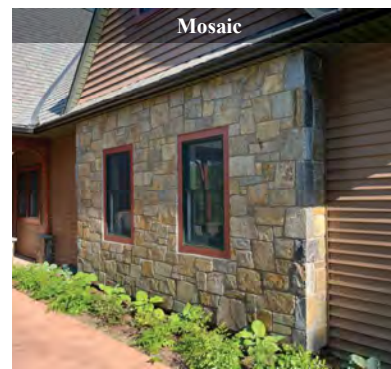

Mosaic



Mosaic

Wood Creek

This granite features a dynamic range of light to dark gray tones, accented by subtle blue undertones. Flowing white striations create natural movement, while occasional quartz and mica inclusions add depth and refined character.



Ashlar

Flats \$19.05/sq ft
Corners \$22.60/lin ft
Full Bed \$650/ton



Squares & Rectangles

Flats \$19.05/sq ft
Corners \$22.60/lin ft
Full Bed \$650/ton

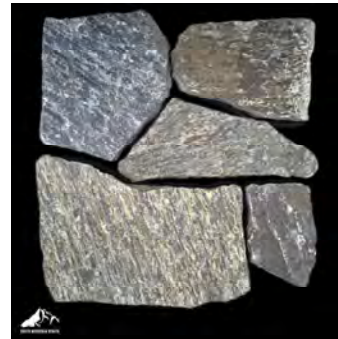

Mosaic

Flats \$19.05/sq ft
Corners \$22.60/lin ft
Full Bed \$590/ton



Ledge

Flats \$19.05/sq ft
Corners \$22.60/lin ft
Full Bed \$655/ton



Squares & Rectangles



Squares & Rectangles



Mosaic

Wall Stone



South Bay Quartzite Cottage Wall 3" x 8"

\$475/ton \$595 - \$785/pallet

17 - 21 cubic feet
2,500 - 3,300 lbs per pallet

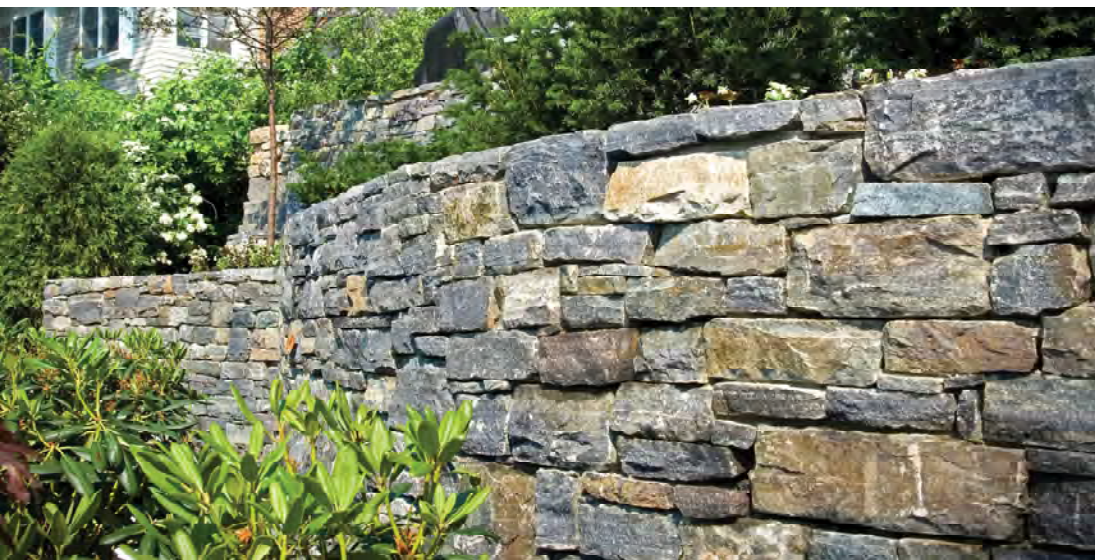

Saratoga Granite Blend Cottage Wall 3" x 8"

\$475/ton \$595 - \$785/pallet

17 - 21 cubic feet
2,500 - 3,300 lbs per pallet



Ticonderoga Granite Blend Cottage Wall 3" x 8"

\$475/ton \$595 - \$785/pallet

17 - 21 cubic feet
2,500 - 3,300 lbs per pallet

Wall Stone



Rustic Tumbled Bluestone

Thin 1" - 3"

\$665/pallet

27 cubic feet
3,000 lbs per pallet



Pocono Blend

\$490/pallet

28 cubic feet
3,000 lbs per pallet



Laredo Wall Blocks, Greystone

\$8.50/regular block

100 peices per pallet

2,800 lbs per pallet

Length 11.44" x Width 7.63" x Heigh 3.82"



\$5.50/tapered unit

150 peices per pallet

2,700 lbs per pallet

Outside Width 7.88"

Inside Width 6.06"

Depth 7.63"

Heigh 3.82"

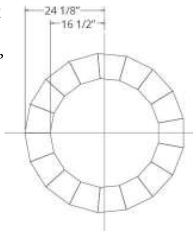

Wall Stone



Colonial Wall Stone

Thin 1" - 3"

\$440/pallet

30 cubic feet
3,000 lbs per pallet



Colonial Wall Stone

Medium 2" - 5"

\$440/pallet

30 cubic feet
3,000 lbs per pallet



Colonial Wall Caps

2" - 4" x 12"-24"

\$480/pallet

15 - 30 pieces
3,000 lbs per pallet

Wall Stone



Natural Field Stone Thin 1" - 3"

\$500/pallet
30 cubic feet
3,000 lbs per pallet



Natural Field Stone Medium 3" - 6"

\$500/pallet
30 cubic feet
3,000 lbs per pallet



West Mountain Thin 1" - 2"

\$530/pallet
27 cubic feet
3,000 lbs per pallet



West Mountain Thick 4" - 6"

\$460/pallet
27 cubic feet
3,000 lbs per pallet



Wall Stone



Vermont Mountain Weathered Wallstone

\$475/pallet

24 cubic feet
3,000 lbs per pallet



Vermont Mountain Split Faced Wallstone

\$515/pallet

24 cubic feet
3,000 lbs per pallet



Vermont Mountain Small Wallstone

\$315/pallet

12 cubic feet
1,500 lbs per pallet



Vermont Mountain Capstones

\$39/square foot

16" -20" x 3" - 5"
12-18 square feet
1,000 lbs per pallet



Edging & Border



Belgium Blocks

Regular
5" x 5" x 9"

140 pieces/pallet

Grey \$6.50/each
Pink \$7.30/each
Buff \$8.50/each
Black \$9.20/each

Jumbo
10" x 4" x 7"

100 pieces/pallet

Grey \$8.50/each
Pink \$10.00/each
Buff \$12.00/each
Black \$13.00/each

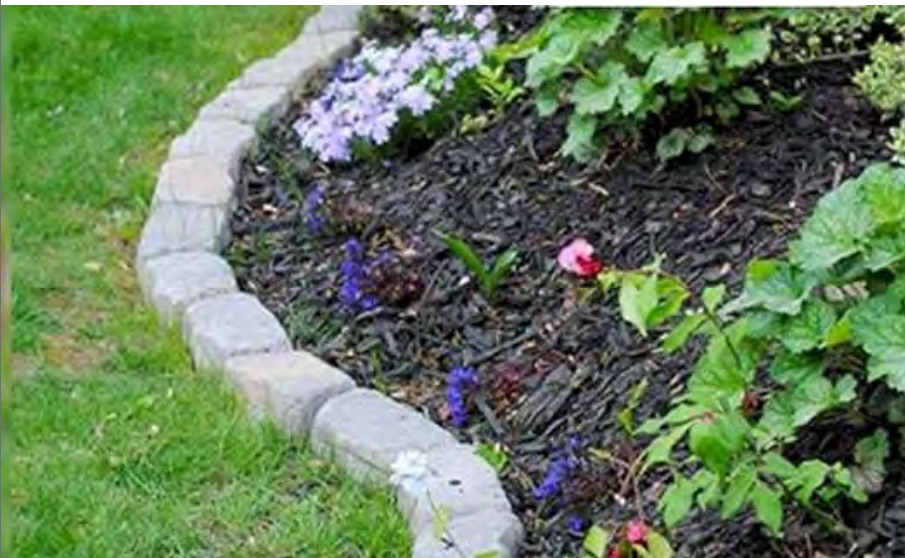

Tumbled Bluestone Edging

5" x 5" x 10"
\$9.25/each

5" x 5" x 12"
\$11.00/each



Fronterra Chartan Edging

4" x 6" x 14"
108 pieces/pallet

\$8.50/each

Garden Path



Rustic Tumbled Bluestone

\$720/ton \$900-\$1,100/pallet

2" -5" x 24" - 48"

10 - 18 pieces, 3,000 lbs per pallet



Bluestone Round Garden Steppers

\$695/pallet

7 pieces per pallet



Natural Field Stone Steppers

\$515/pallet

2" -5" x 24" - 48"

10 - 18 pieces, 3,000 lbs per pallet



Hand Worked Stepping Stones

\$25/each

16" x 1 1/4"

Sold individually or 56 pieces per pallet



Irregular Patio & Walkway



**Full Color Bluestone
Natural Cleft**

\$520/ton \$750 - \$1,100/pallet

1" - 2" x 24" - 48"
100-150 square feet per pallet
2,800 - 4,000 lbs per pallet



**Bluestone
Thermal**

\$880/ton \$1,200 - \$1,800/pallet

1" - 2" x 24" - 48"
100-150 square feet per pallet
2,800 - 4,000 lbs per pallet



Tumbled Bluestone

\$625/pallet
2" - 3" x 12" - 24"
100-120 square feet per pallet
3,000 lbs per pallet



Irregular Patio & Walkway



**South Bay Quartzite
Natural Cleft**

\$670/ton \$1,150 - \$1,400/pallet

1" - 3" x 18" - 48"
115 - 150 square feet per pallet
3,500 - 4,200 lbs per pallet



**West Mountain
Thermal**

\$990/ton \$1,800 - \$2,100/pallet

1" - 2" x 18" - 48"
150 - 180 square feet per pallet
3,800 - 4,200 lbs per pallet



**Saratoga Granite Blend
Natural Cleft**

\$615/ton \$1,100 - \$1,300/pallet

1" - 3" x 18" - 48"
115 - 150 square feet per pallet
3,500 - 4,200 lbs per pallet

Pattern Cut Patio & Walkway



Thermal Bluestone

\$16.50+/sq ft
Sold per piece

1' x 1' x 1.5"	\$16.50/sf	2' x 4' x 1.5"	\$24.50/sf
1' x 2' x 1.5"	\$16.50/sf	3' x 3' x 1.5"	\$23.00/sf
2' x 2' x 1.5"	\$16.50/sf	4' x 4' x 1.5"	\$33.00/sf
2' x 3' x 1.5"	\$16.50/sf		

Patio On A Pallet

100 square feet per pallet

Thermal True Blue \$1,650/pallet
Thermal Full Color \$1,500/pallet



Natural Cleft Bluestone

\$12.50+/sq ft
Sold in full pallet quantities

1' x 1' x 1.5"	\$12.50/sf	2' x 4' x 1.5"	\$20.50/sf
1' x 2' x 1.5"	\$12.50/sf	3' x 3' x 1.5"	\$19.00/sf
2' x 2' x 1.5"	\$12.50/sf	4' x 4' x 1.5"	\$30.00/sf
2' x 3' x 1.5"	\$12.50/sf		

Patio On A Pallet

100 square feet per pallet

Natural Cleft True Blue \$1,400/pallet
Natural Cleft Full Color \$1,250/pallet



Pattern Cut Patio & Walkway



Cut & Tumbled Bluestone

\$14.50/sq ft
Sold per piece

6" x 6" x 2"
6" x 12" x 2"
12" x 12" x 2"
12" x 18" x 2"



Cut & Tumbled West Mountain

\$23.00/sq ft
Sold in full pallet quantities

6" x 6" x 2"
6" x 12" x 2"
12" x 12" x 2"
12" x 18" x 2"

Pattern Cut Patio & Walkway



Thermal West Mountain

\$21.50/sq ft
Sold in full pallet quantities

- 1' x 1' x 1.5" \$21.50/sf
- 1' x 2' x 1.5" \$21.50/sf
- 2' x 2' x 1.5" \$21.50/sf
- 2' x 3' x 1.5" \$21.50/sf



Thermal Grey Granite

\$27.50/sq ft
Sold per piece

- 1' x 1' x 1.25" \$16.50/sf
- 1' x 2' x 1.25" \$16.50/sf
- 2' x 2' x 1.25" \$16.50/sf
- 2' x 3' x 1.25" \$16.50/sf



Natural Cleft Vermont Slate

- \$11.00/sq ft
6" x 12" x 1" - 12" x 18" x 1"
- \$13.00/sq ft
18" x 18" x 1" - 18" x 24" x 1"
- \$16.00/sq ft
24" x 24" x 1" - 24" x 36" x 1"



Paver Patio & Walkway



Ridgefield Plus Pavers Champagne

\$9.65/square foot

Sold per layer of 11.63 sq ft
four of each size per layer
93 sq ft, 3,004 lbs per pallet



8" x 12" x 2.76"



12" x 12" x 2.76"



12" x 16" x 2.76"



Nueva Pavers Champagne

\$11.50/square foot

Sold per layer of 12.9 sq ft
three 8x16, three 16x16,
three 16x24 pieces per layer
77.5 sq ft, 2,930 lbs per pallet



8" x 16" x 3.15"



16" x 16" x 3.15"



16" x 24" x 3.15"



Collonade Pavers Greyfield

\$8.60/square foot

Sizes sold individually by the layer



6" x 6" and 3" x 6" x 2.36"
sold as a combo, 11.56 sq ft,
18pcs 3"x6" + 45pcs 6"x6" per layer
104 sq ft, 2,925 lbs per pallet



6" x 9" x 2.36"
11.55 sq ft, 32 pcs per layer
105 sq ft, 2,826 lbs per pallet



9" x 9" x 2.36"
10.88 sq ft, 20 pcs per layer
98 sq ft, 2,750 lbs per pallet



9" x 12" x 2.36"
11.55 sq ft, 16 pcs per layer
104 sq ft, 2,936 lbs per pallet

Regular Stone Steps



Thermal Bluestone

4' x 18" - 20" x 6" \$425 each

6' x 18" - 20" x 6" \$615 each

8' x 18" - 20" x 6" \$795 each



Natural Edge Bluestone

3' x 16" - 20" x 6" \$325 each

4' x 16" - 20" x 6" \$385 each

5' x 16" - 20" x 6" \$465 each

6' x 16" - 20" x 6" \$545 each

8' x 16" - 20" x 6" \$785 each



Tumbled Bluestone

3' x 18" x 6" \$365 each

4' x 18" x 6" \$445 each

5' x 18" x 6" \$545 each



Caledonia Granite

4' x 18" - 20" x 7" \$660 each

6' x 18" - 20" x 7" \$960 each



Regular Stone Steps

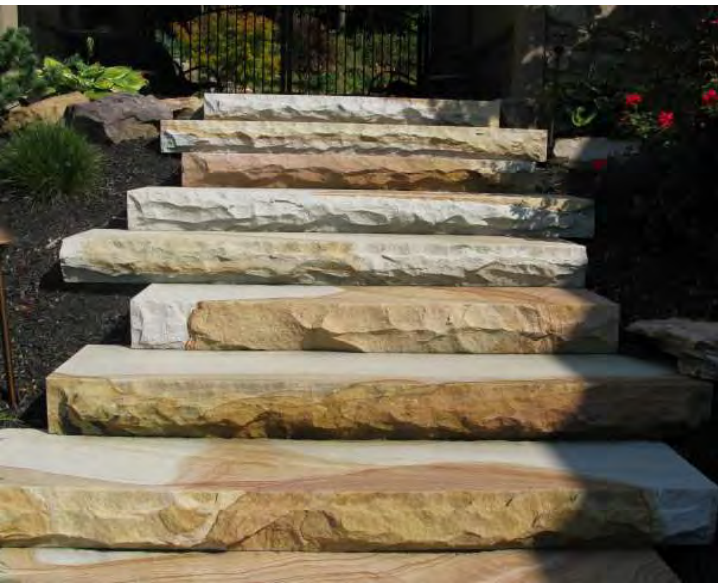

Rock Face West Mountain

4' x 18" x 6" \$555 each
6' x 18" x 6" \$795 each



Thermal West Mountain

4' x 18" x 6" \$495 each
6' x 18" x 6" \$705 each



Vermont Woodbury Grey Granite

4' x 18" x 7" \$540 each
6' x 18" x 7" \$770 each
16" x 7" Filler \$65 each



Vermont Woodbury Grey Granite Doorstep Millstone

4' x 2' x 7" \$925 each



Irregular Stone Step Slabs



Saratoga Granite Blend

16" - 60" x 5" - 8"
\$250+ each



South Bay Quartzite

16" - 60" x 5" - 8"
\$270+ each



Ticonderoga Granite Blend

16" - 60" x 5" - 8"
\$250+ each

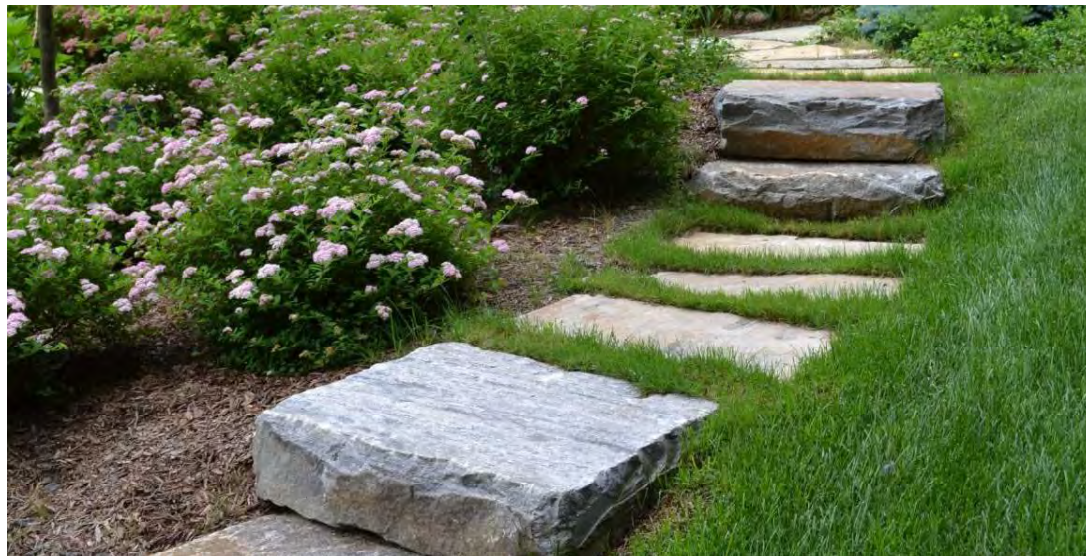

Irregular Stone Step Slabs



Natural Fieldstone

24" - 48" x 4" - 6"
\$175+ each

24" - 48" x 6" - 8"
\$250+ each



Vermont Mountain Stone

16" - 96" x 5" - 10"
\$260+ each



Vermont Slate Slabs

Available in many
sizes and colors

\$250+ each

Irregular Stone Step Slabs



Full Color Bluestone

24" - 48" x 4" - 6"
\$200+ each

24" - 108" x 6" - 10"
\$275+ each



West Mountain Thick Slabs

24" - 60" x 4" - 6"
\$250+ each



West Mountain Thin Slabs

36" - 96" x 2"
\$52/square foot

36" - 96" x 3"
\$64/square foot



Stone Treads



Thermal Bluestone

- 6' x 18" x 2" \$266 each
- 6' x 24" x 2" \$366 each
- 8' x 18" x 2" \$354 each
- 8' x 24" x 2" \$488 each

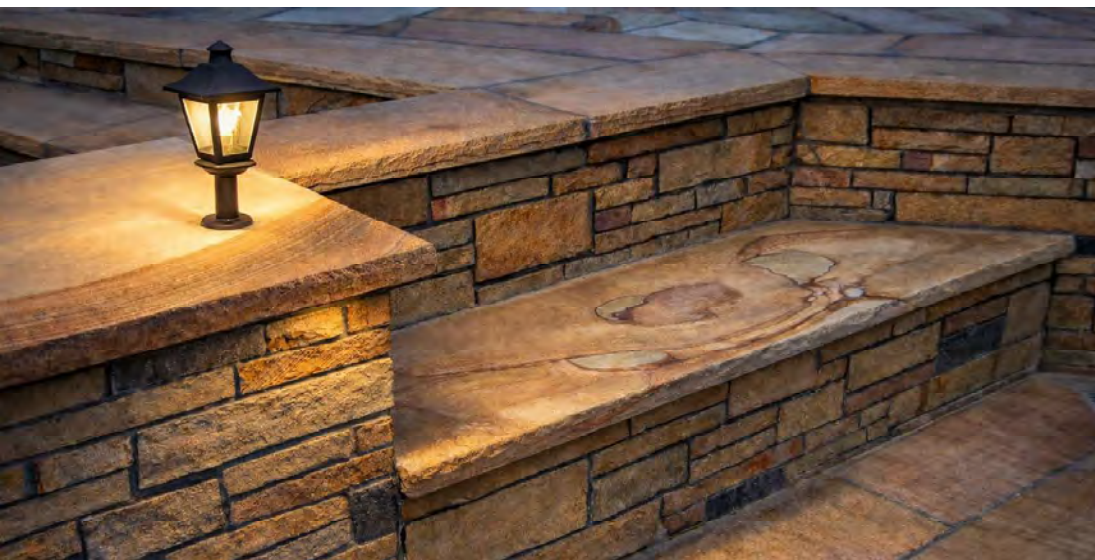

Thermal West Mountain

Sold in full pallet quantities

- 6' x 18" x 2" \$333 each
- 6' x 24" x 2" \$450 each
- 8' x 18" x 2" \$444 each
- 8' x 24" x 2" \$600 each



Vermont Woodbury Grey Granite

- 6' x 18" x 2" \$468 each
- 6' x 24" x 2" \$624 each
- 8' x 18" x 2" \$624 each
- 8' x 24" x 2" \$832 each

Stone Benches



Rectangular Bench

48" x 14" x 4" bench top with two legs, split face edges, sandblasted top
VT Woodbury Grey Granite \$610
Caledonia Granite \$730



Curved Bench

48" x 14" x 4" bench top with two legs, split face edges, sandblasted top
VT Woodbury Grey Granite \$790
Caledonia Granite \$930



Kidney Bench

46" long x 4" bench top with two legs, split face edges, sandblasted top
VT Woodbury Grey Granite \$735
Caledonia Granite \$930



Natural Stone Bench

Available in various sizes and colors



Bluestone Bench with Back

5' long, thermal finish, smoothed edges
Solid Back \$895



Bluestone Bench with Back

5' long, thermal finish, smoothed edges
Patterned Back \$895

Decorative Accents



Stone Garden Spires
Available in various sizes and colors
\$225+ each



Decorative Boulders
Various sizes and types available



Kewanee Skippers
1" - 3" x 4" - 7"
\$1.00/lb loose \$320/325 lb bag



Mexican Beach Pebbles
2" - 3"
\$1.00/lb loose \$320/325 lb bag



Bluestone Plant Holder
Thermal Finish
\$145 each



Granite Lamp Post
6" x 6" x 8'0"
\$745 each



Granite Mailbox Post
7" x 7" x 7'0"
\$575 each

Bulk Landscaping Products



River Stone
1 1/2" Clean \$65/cubic yard



Vermont Winter White
1 1/2" Clean \$65/cubic yard



Champlain Blue
1 1/2" Clean \$62/cubic yard



Sunset Blend
3/4" Clean \$80/cubic yard



River Stone
3/4" Clean \$60/cubic yard



Vermont Winter White
3/4" Clean \$78/cubic yard



Champlain Blue
3/4" Clean \$65/cubic yard

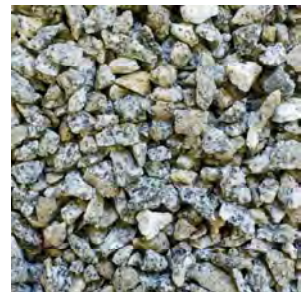

Crushed Granite
3/4" Clean \$86/cubic yard

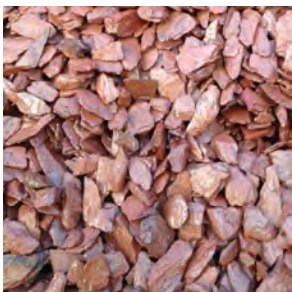

Indian River Red
3/4" Clean \$86/cubic yard



Vermont Winter White
Driveway Mix \$65/cubic yard



Champlain Blue
Driveway Mix \$59/cubic yard



Black Ground Asphalt
Driveway Mix \$85 cubic yard



Indian River Red
Driveway Mix \$76/cubic yard



Plum
Driveway Mix \$73/cubic yard



Champlain Blue
Rock Fines \$80/cubic yard



3/4" Gravel
\$58/cubic yard



Pea Stone
3/8" Clean \$61/cubic yard



Mexican Beach Pebbles
2" - 3" 325lb sack for \$320



Kewanee Skippers
1" - 3" x 4" - 7" 325lb sack for \$320



Play Sand
\$59/cubic yard



Hemlock Mulch
\$75/cubic yard



Forest Blend Mulch
\$65/cubic yard



Straw
\$14/bale



Premium Grass Seed
\$140/25lb bag \$32/5lb bag



Top Soil
\$56/cubic yard



Compost
\$80/cubic yard



Premium Garden Mix
\$70/cubic yard

All bulk products are available for pick up or delivery. We have experienced drivers and a fleet of trucks ready to bring the products you need to your location.



★★★★★

"I bought a few yards of crushed stone from Livingston Farm. The quality was excellent and the price was fair. Most importantly, the customer service was superb! For them, this was a pretty small sale, but they treated me as if I were their most important customer. I'd definitely buy from them again!"

LES M. ~ BURLINGTON, VT



Recommended Installation Guides

Double faced free standing wall

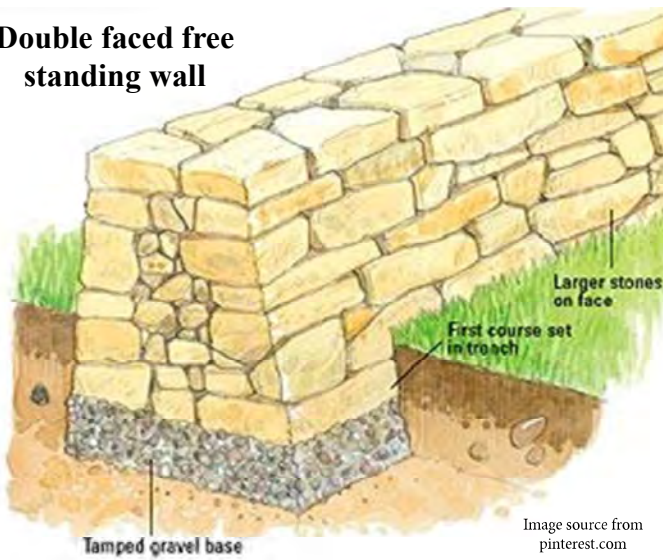

Image source from [pinterest.com](https://www.pinterest.com)

★★★★★

“Responsive, helpful, friendly, informative (I’d never done a DIY patio before and they gave me the answers to the questions I didn’t know I needed to ask), all-around a fantastic family operation.”

Dave B. ~ Vermont

Stone walkway and patio

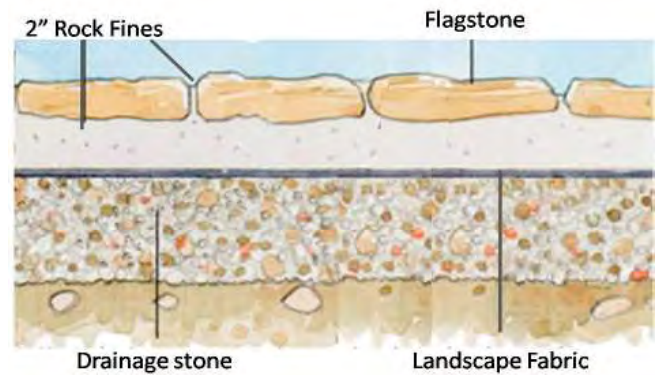

Retaining wall

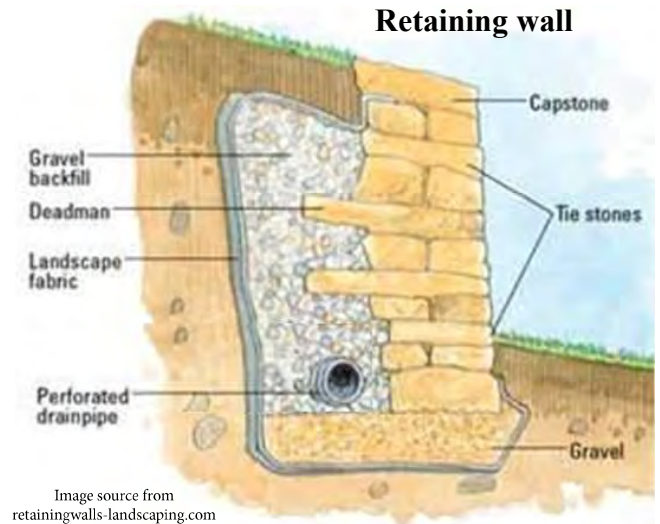

Image source from [retainingwalls-landscaping.com](https://www.retainingwalls-landscaping.com)



Which ADU is right for you?

The Haven



It's all done, just bring your toothbrush! Our *move-in ready ADU* is a fully finished space thoughtfully crafted and offers instant livability. From the kitchen to the bathroom, every detail has been designed for comfort, style and convenience.

Tiny Home



Pre-built tiny home ideal for relaxed, seasonal living. Designed for simple, comfortable, living, these *three season tiny homes* offer a practical retreat without the complexity of a full-scale build. These thoughtfully constructed homes provide a ready to use space for weekend getaways, seasonal camps or a peaceful escape from everyday life.

Kick Starter



Your vision, your way. Our *Unfinished Shell ADU* is the perfect blank canvas for DIYers, contractors, and budget conscious buyers who want to customize their livable space from the ground up. We'll provide the weather tight shell so you can finish at your own pace.

Accessory Building



We do the heavy lifting, you make it shine. Our Accessory Building is a *finished shell* offering a fully enclosed, insulated, and wired building. With endless uses, this structure will expand your living space. This mid-tier option saves you time and money.

Features	The Haven	Tiny Home	ADU Kick Starter	Accessory Building
What makes it special	A ready-to-use, beautifully finished, turn key home with no hassles and no surprises.	The compact layout offers a warm, inviting feel. Durable construction and efficient design make it well suited for spring, summer, and fall use.	Save up front with this shell. Install electric, plumbing and insulation, then personalize your layout, finishes and utilities.	With a completely insulated and wired building, you get to customize your exterior wall layout and add the personal touches that will suit your use.
Best For	Busy professionals, those needing extra space or those looking to downsize or simplify	Those seeking a comfortable, pre-built recreational retreat they can enjoy right away	Owner-builders, hobbyists, those wanting flexibility, phased projects	Those seeking a backyard office, creative studio, personal gym, or flexible space for changing needs
Framed, weather tight shell	YES	YES	YES	YES
Insulated windows	YES	YES	YES	YES, entry level insulated
Insulated exterior doors	YES	YES	YES	YES
Flooring	Finished Flooring and spray foam insulation included	Finished flooring and spray foam insulation included	Durable plywood subfloor. Sprayfoam insulation included	Finished flooring and spray foam insulation included
Insulated Roof	YES	YES	NO	YES
Interior Walls	Partitioned, painted and insulated	Partitioned, painted and insulated	2x6 Exposed framing	Painted wood panels on 2x4 or 2x6 insulated walls
Interior layout	Turnkey floor plan with kitchen, living, bath, bedroom layout	Turnkey floor plan with kitchen, living, bath, bedroom(s) layout	Ready for you to design	Ready for you to design
Plumbing	YES	YES	NO	NO
Electrical, fixtures and appliances	Included	Included	NO	Electric wiring and receptacles installed, no fixtures or appliances
Layout design flexibility	NO	NO	YES	YES
Upgrades available	Only siding color	Only siding color	YES	YES

The Haven

\$135,000



Luxurious Four Season Micro Mansion

- 11'6" x 40'4"
- 464 square feet
- one bedroom
- kitchen with appliances
- dining area
- full bathroom
- living room
- crawl loft space

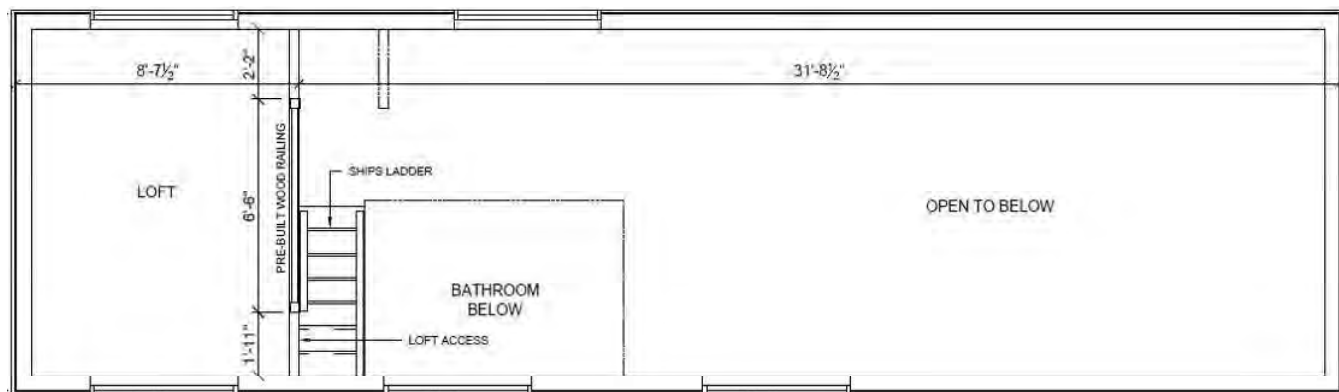
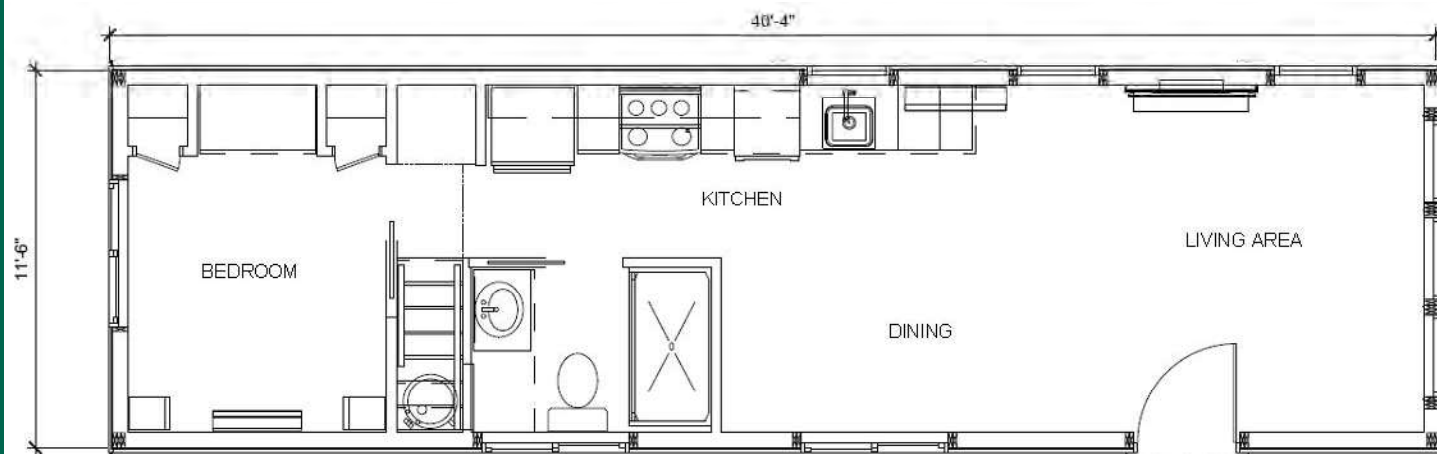

Standard Features:

Construction Details:

- 11'6" wide x 40'4" long x 11'1" to peak (464 sq ft)
- Vinyl board & batten vertical siding
- Vinyl shake accent finish
- Timber frame accents
- 1" x 6" Miratec fascia
- 4" x 4" Pressure treated runners
- 2" x 8" Floor joists@ 16" on center
- 2" x 6" wall studs with moisture barrier house wrap
- Truss roof system with a 2:12 roof pitch
- Polycon closed cell spray foam insulation
 - R21 in walls
 - R30 in floor
 - R49 in ceiling
- Provia Heritage fiberglass entry door
- Insulated vinyl black windows

Interior Details:

- 20 Gallon electric water heater
- Nortek mini split system:
 - two units (bedroom and main room)
- Electrical package includes 100 amp service with receptacles and lights
- Ships ladder to carpeted loft
- Storage cabinets and dresser in bedroom
- Smoke/carbon monoxide detectors
- Fire extinguisher
- Fireplace feature with wood mantel
- Luxury vinyl flooring in Barn Wood Buckhorn

Kitchen Details:

- Shaker style cabinets in Snow with soft-close drawers and doors
- Tile backsplash
- Laminate countertops in Smokey Topaz
- Stainless Steel Appliances:
 - Whirlpool Dishwasher #WDF341PAPM
 - Whirlpool Freestanding Gas Range #WFG320MDMS
 - Whirlpool Top-Freezer Refrigerator #WRT311FZD
 - 20 cubic feet capacity, with ice maker
 - Whirlpool Over the Range Microwave Hood
 - Combination: 1.7 cubic feet #WMH31017HB

Bathroom Details:

- 30" Vanity cabinet with mirror
- 7' Walk in tile shower with glass door
- ADA Compliant flush tank toilet

Optional Furniture Package: +\$4,950

- Sofa
- Dining table with seating for four
- Accent chair
- Lift up queen bed with storage
- Coffee table
- Two nightstands

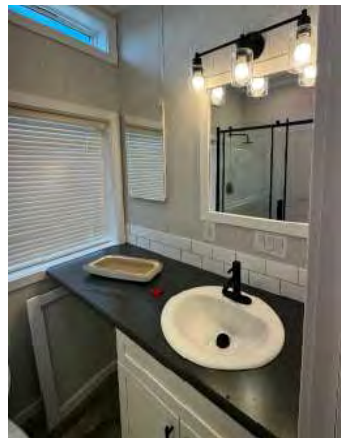
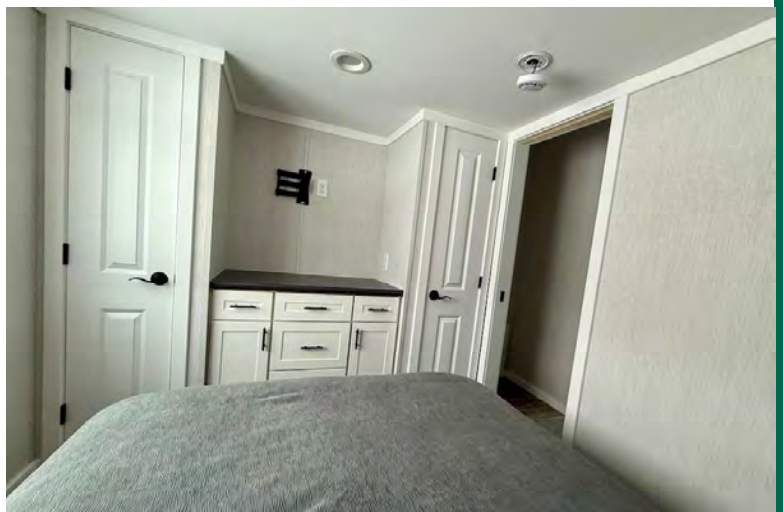

The Prestige

\$88,700



The Prestige \$80,100
without covered deck



The Perfect Private Getaway

- 12'0" x 33'0"
- 396 square feet
- 8' covered deck (optional)
- one bedroom
- kitchen with appliances
- dining/living area
- bathroom

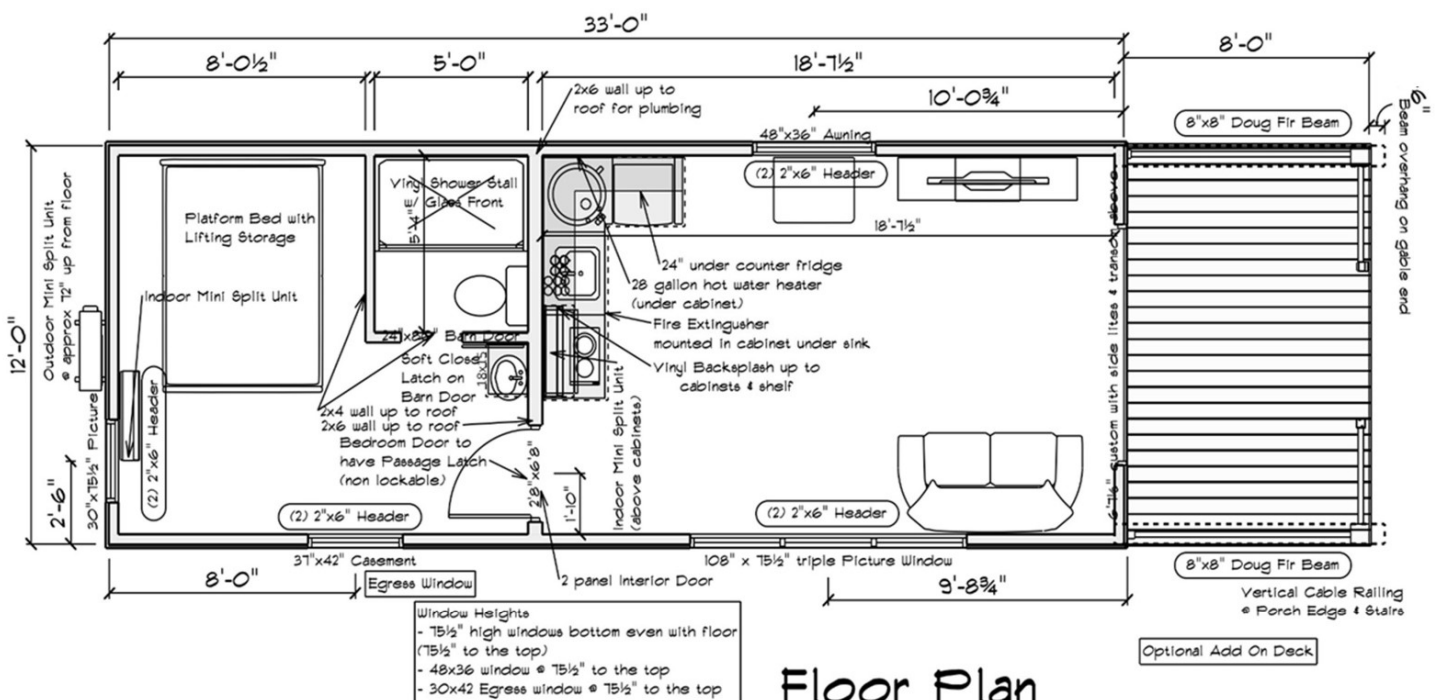

Floor Plan



The Perennial

\$108,400



A Family Retreat Built For Memories

- 11'2" x 35'0"
- 396 square feet
- two bedrooms
- kitchen with appliances
- dining/living area
- full bathroom

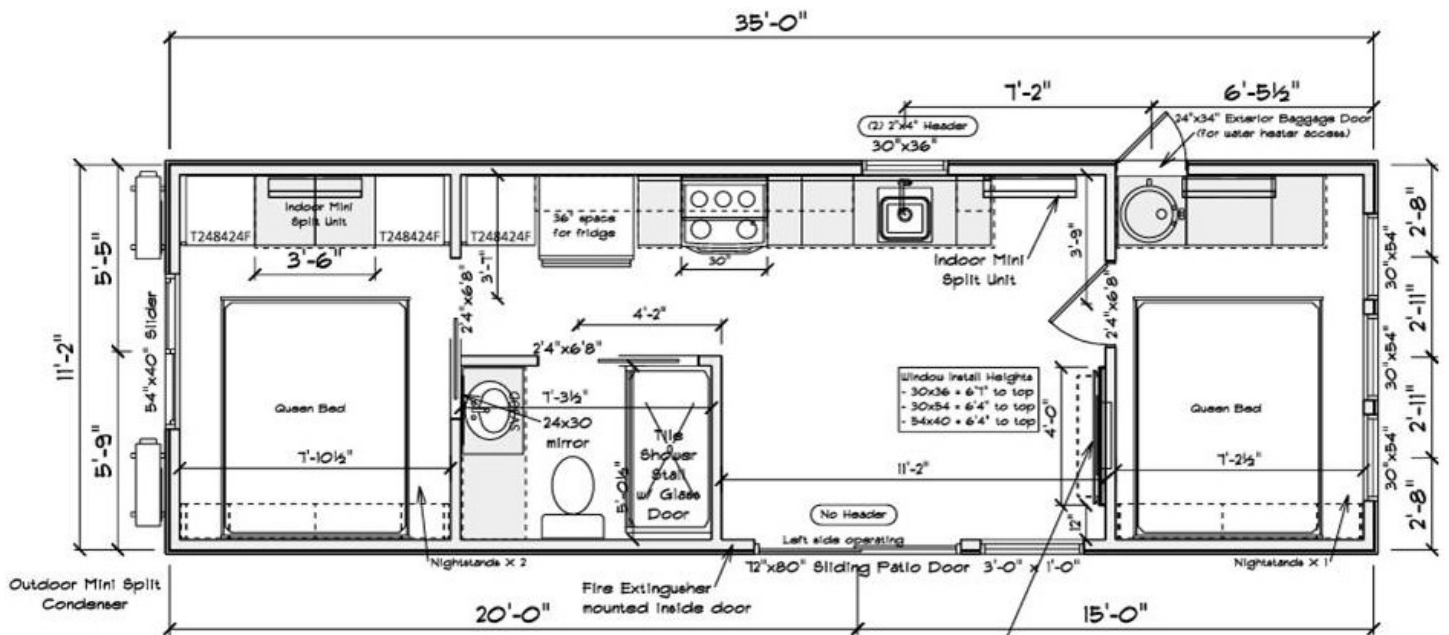

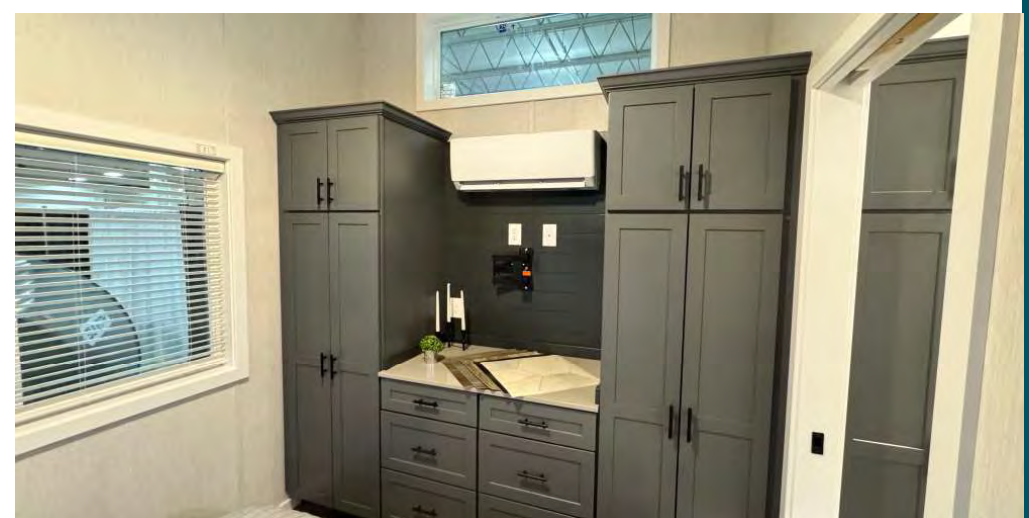
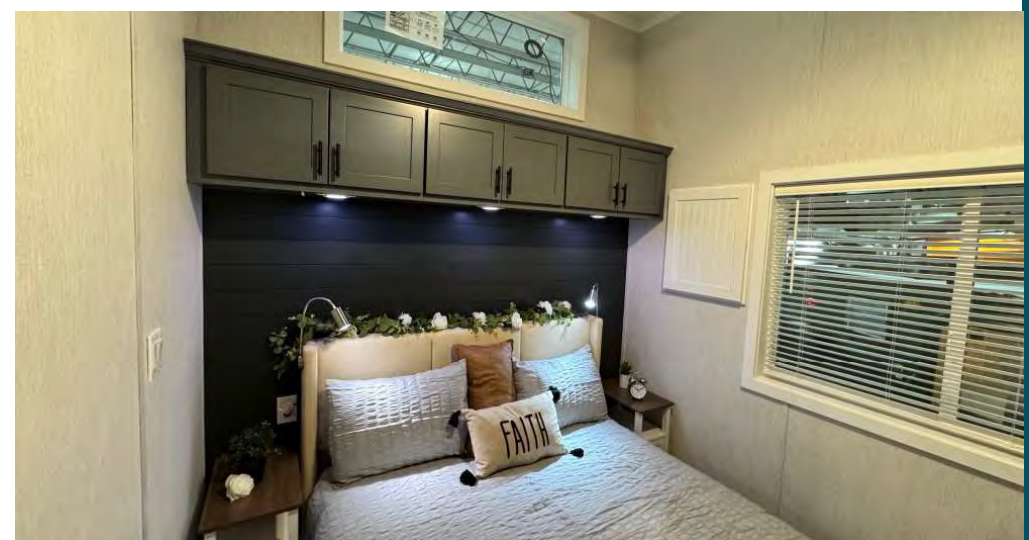

The Vista

\$113,400



Where The Day Slows Down

- 11'0" x 36'8"
- 399 square feet
- one bedroom
- single loft
- dine in kitchen with appliances
- living area
- full bathroom

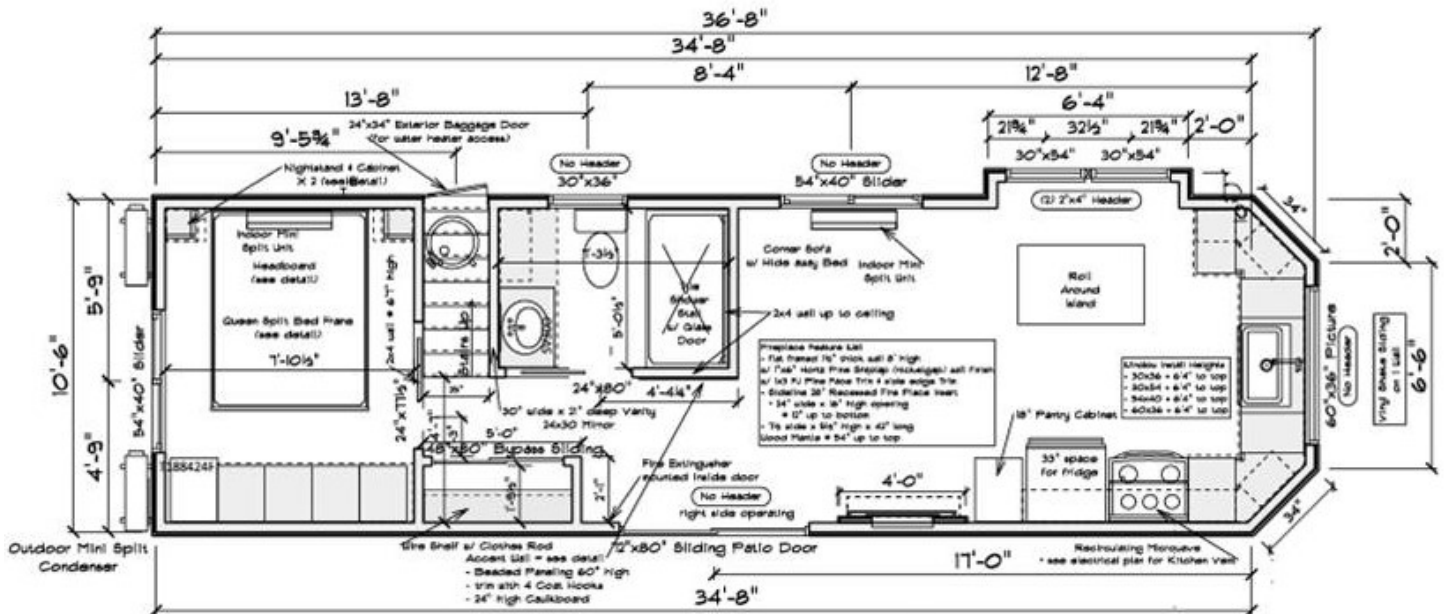

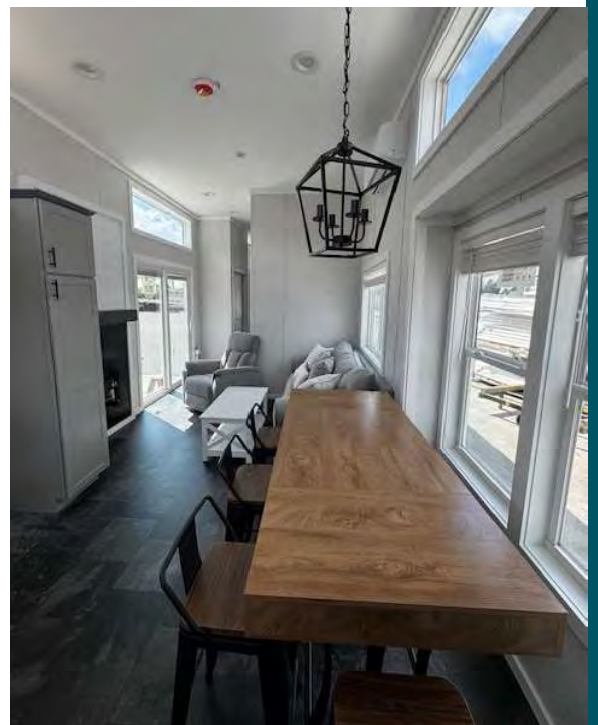

The Summit

\$111,200



Where Smart Spaces Create Easy Living

- 10'10" x 36'4"
- 399 square feet
- two bedrooms
- single loft
- full bathroom
- dining/living area
- kitchen with appliances

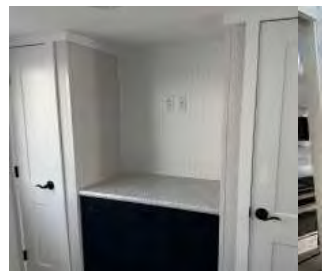
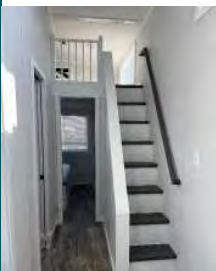
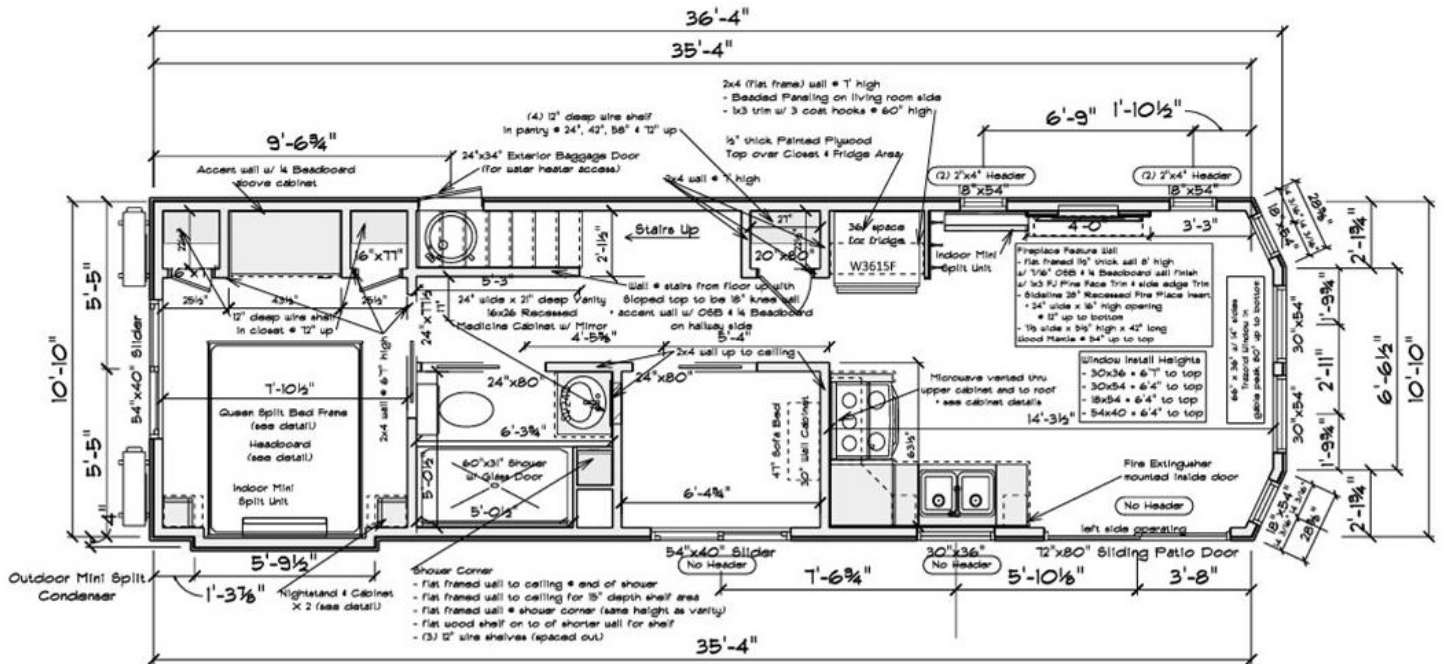

The Ovation

\$105,200



Discover Spacious Serenity

- 11'2" x 35'0"
- 392 square feet
- dining area
- living area
- one king bedroom
- full bathroom
- kitchen with appliances

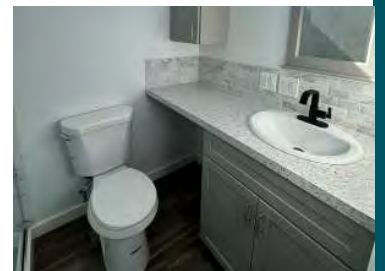
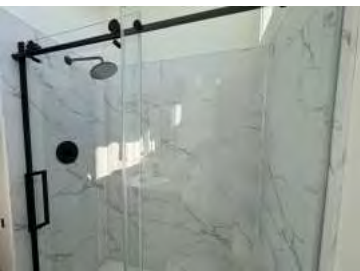
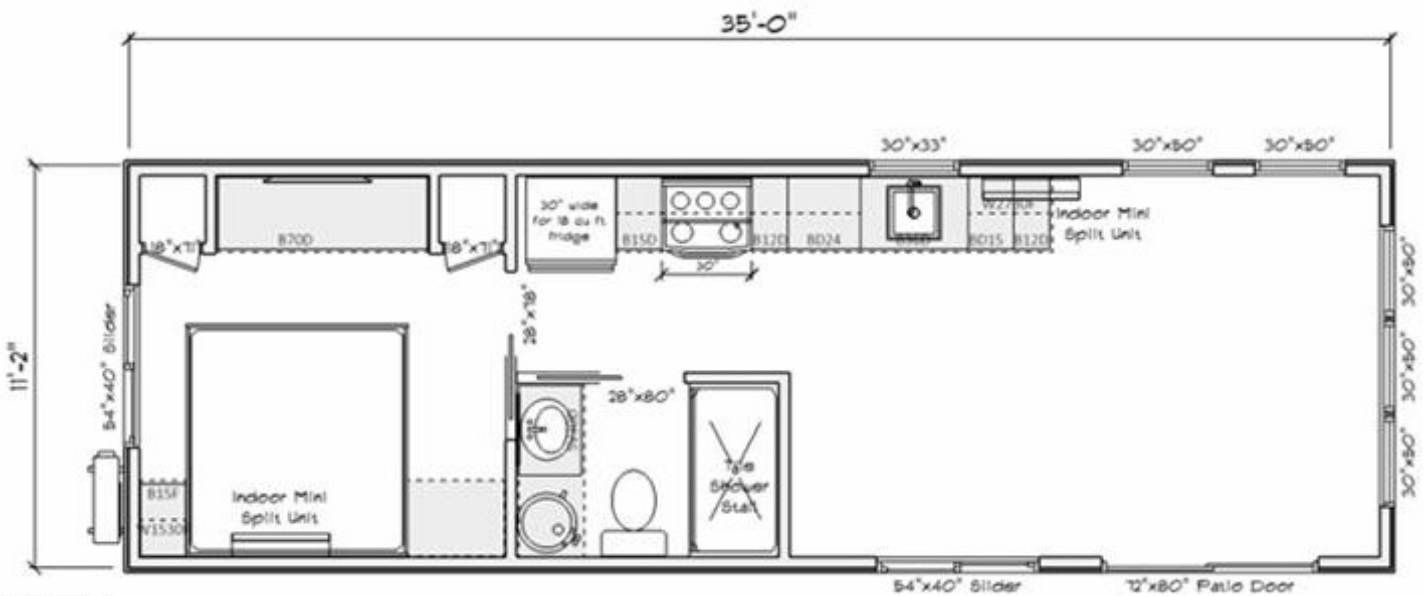

Royal Two Story



20' x 24' shown

Two Story Double Wide Royal Victorian Dutch Barn

Standard Features:

- LP Engineered Wood Siding
- 9' Sidewalls
- 2" x 6" Wall Studs 16" On Center
- 1" x 4" Miratec Trim
- 30 year Architectural Shingles
- 2" x 8" Rafters 16" On Center
- 12" Roof Overhang on Gable ends
- Stairway to Full Upstairs Loft
- 3'w x 6'8"h Insulated Door
- Four 24" x 36" White Insulated Windows
- Four Sets of Z-style Shutters
- Permanent Wood Floor
- 2" x 6" Floor Joists 12" On Center
- 4" Spray Foam (R28) Floor Insulation
- Pressure Treated Runners

KICK STARTER Two Story Double Wide		
Square feet Total	WxL	DUTCH BARN
640	16x20	\$55,514
768	16x24	\$62,244
800	20x20	\$74,726
864	18x24	\$66,603
960	20x24	\$82,075
1008	18x28	\$73,394
1120	20x28	\$89,123
1152	24x24	\$90,575
1344	24x28	\$98,731
1568	28x28	\$106,353

FREE DELIVERY and On Site Assembly within 25 miles!

All Royal buildings are customizable. See pages 64 and 65 for more options.



16' x 20' shown



18' x 28' shown



16' x 20' shown

Victorian Double Wide



16' x 28' shown

Two Story Double Wide Royal Victorian

Aframe

KICK STARTER Two Story Double Wide			
Square feet Total	WxL	AFRAME 9' Sidelwalls	AFRAME 10' Sidelwalls
640	16x20	\$54,514	\$55,522
768	16x24	\$61,144	\$62,264
800	20x20	\$73,442	\$74,562
864	18x24	\$65,689	\$66,865
960	20x24	\$80,791	\$82,023
1008	18x28	\$72,668	\$73,954
1120	20x28	\$87,839	\$89,183
1152	24x24	\$89,291	\$90,635
1344	24x28	\$97,447	\$98,903
1568	28x28	\$105,269	\$106,837

Standard Features:

- LP Engineered Wood Siding
- 2" x 6" Wall Studs 16" On Center
- 1" x 4" Miratec Trim
- 30 year Architectural Shingles
- 2" x 8" Rafters 16" On Center
- 12" Roof Overhang
- Stairway to Full Upstairs Loft
- 3'w x 6'8"h Insulated Door
- Four 24" x 36" White Insulated Windows
- Four Sets of Z-style Shutters
- Permanent Wood Floor
- 2" x 6" Floor Joists 12" On Center
- 4" Spray Foam (R28) Floor Insulation
- Pressure Treated Runners

FREE DELIVERY and On Site Assembly within 25 miles!

All Royal buildings are customizable. See pages 64 and 65 for more options.



24' x 24' shown



24' x 24' shown



24' x 32' shown

Royal Two Story



14' x 28' shown

Two Story Single Wide Royal Victorian

Dutch Barn

Standard Features:

- LP Engineered Wood Siding
- 9' Sidewalls
- 2" x 6" Wall Studs 16" On Center
- 1" x 4" Miratec Trim
- 30 year Architectural Shingles
- 2" x 8" Rafters 16" On Center
- 12" Roof Overhang on Gable ends
- Stairway to Full Upstairs Loft
- 3'w x 6'8"h Insulated Door
- Four 24" x 36" White Insulated Windows
- Four Sets of Z-style Shutters
- Permanent Wood Floor
- 2" x 6" Floor Joists 12" On Center
- 4" Spray Foam (R28) Floor Insulation
- Pressure Treated Runners

KICK STARTER Two Story Single Wide		
Square feet Total	WxL	DUTCH BARN
384	12x16	\$35,737
432	12x18	\$37,947
480	12x20	\$40,328
560	14x20	\$43,761
576	12x24	\$44,928
616	14x22	\$46,156
672	12x28	\$49,631
672	14x24	\$48,534
728	14x26	\$51,056
784	14x28	\$53,752

FREE DELIVERY and On Site Assembly within 25 miles!

All Royal buildings are customizable. See pages 64 and 65 for more options.



14' x 28' shown



14' x 28' shown



14' x 24' shown

Victorian

Single Wide



14' x 30' shown

Two Story Single Wide Royal Victorian

Aframe

Standard Features:

- LP Engineered Wood Siding
- 10' Sidewalls
- 2" x 6" Wall Studs 16" On Center
- 1" x 4" Miratec Trim
- 30 year Architectural Shingles
- 2" x 8" Rafters 16" On Center
- 12" Roof Overhang
- Stairway to Full Upstairs Loft
- 3'w x 6'8"h Insulated Door
- Four 24" x 36" White Insulated Windows
- Four Sets of Z-style Shutters
- Permanent Wood Floor
- 2" x 6" Floor Joists 12" On Center
- 4" Spray Foam (R28) Floor Insulation
- Pressure Treated Runners

KICK STARTER Two Story Single Wide		
Square feet Total	WxL	AFRAME
384	12x16	\$35,470
432	12x18	\$37,628
480	12x20	\$39,960
560	14x20	\$43,414
576	12x24	\$44,461
616	14x22	\$45,761
672	12x28	\$49,064
672	14x24	\$48,089
728	14x26	\$50,562
784	14x28	\$53,206

FREE DELIVERY and On Site Assembly within 25 miles!

All Royal buildings are customizable. See pages 64 and 65 for more options.

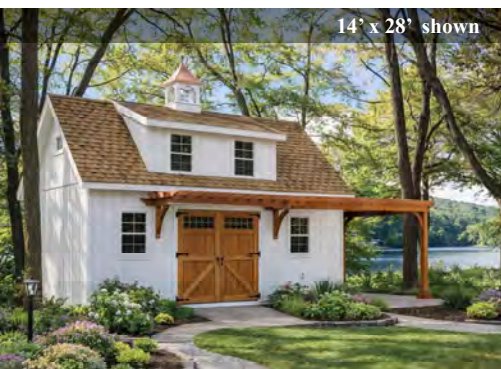

14' x 28' shown



"I can't say enough good things about Livingston Farm. From start to finish, the entire process was seamless, thoughtful, and genuinely a joy. As a family-run business, you can truly feel the care and pride they put into their work, which made the experience even more special for me."

NORA K. ~ BURLINGTON, VT



14' x 24' shown

Royal One Story



14' x 28' shown

One Story Single Wide Royal Victorian

Aframe

Standard Features:

- LP Engineered Wood Siding
- 8' Sidewalls
- 2" x 6" Wall Studs 16" On Center
- 1" x 4" Miratec Trim
- 30 year Architectural Shingles
- 2" x 8" Rafters 16" On Center
- 12" Roof Overhang
- 3'w x 6'8"h Insulated Door
- Four 24" x 36" White Insulated Windows
- Four Sets of Z-style Shutters
- Permanent Wood Floor
- 2" x 6" Floor Joists 12" On Center
- 4" Spray Foam (R28) Floor Insulation
- Pressure Treated Runners

KICK STARTER One Story Single Wide		
Square feet	Width x Length	AFRAME
192	12x16	\$28,924
216	12x18	\$30,538
240	12x20	\$32,315
280	14x20	\$34,713
288	12x24	\$35,916
308	14x22	\$36,692
336	12x28	\$39,613
336	14x24	\$38,637
364	14x26	\$40,722
392	14x28	\$42,973

FREE DELIVERY and On Site Assembly within 25 miles!

All Royal buildings are customizable. See pages 64 and 65 for more options.



14' x 24' shown



12' x 20' shown



14' x 24' shown

Victorian

Single Wide



12' x 22' shown

One Story Single Wide Royal Victorian

Lean To Studio

KICKSTARTER Royal Victorian One Story Single Wide			
Square Feet	Width x Length	LEAN TO STUDIO	# of transoms
160	10' x 16'	\$20,469	4
180	10' x 18'	\$21,581	4
200	10' x 20'	\$23,378	5
220	10' x 22'	\$24,811	5
240	10' x 24'	\$26,453	6
260	10' x 26'	\$27,927	6
280	10' x 28'	\$29,643	7
192	12' x 16'	\$23,044	4
216	12' x 18'	\$24,323	4
240	12' x 20'	\$26,241	5
264	12' x 22'	\$27,861	5
288	12' x 24'	\$29,718	6
312	12' x 26'	\$31,398	6
336	12' x 28'	\$33,325	7

Standard Features:

- LP Engineered Wood Siding
- 2" x 6" Wall Studs 16" On Center
- 1" x 4" Miratec Trim
- 30 year Architectural Shingles
- 2" x 8" Rafters 12" On Center
- 6" Roof Overhang
- 3'w x 6'8"h Insulated Door
- Two 24" x 36" Insulated Windows
- 36" x 36" Insulated Transoms
- Permanent Wood Floor
- Pressure Treated Runners
- 2" x 6" Floor Joists 12" On Center
- 4" Spray Foam (R28) Floor Insulation

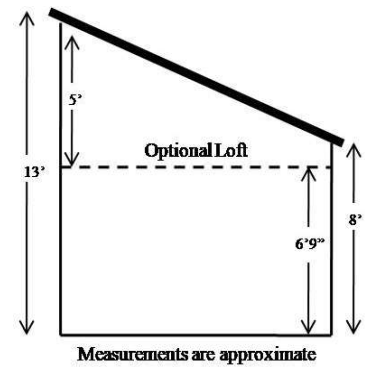

FREE DELIVERY and On Site Assembly within 25 miles!

All Royal buildings are customizable. See pages 64 and 65 for more options.

Add a Loft					
2x8 Loft	4' Long	6' long	8' long	10' long	12' long
10' Wide	\$440	\$660	\$880	\$1,100	\$1,320
12' wide	\$480	\$720	\$960	\$1,200	\$1,440



12' x 24' Interior



12' x 20' shown



12' x 22' shown

Royal Victorian

Customizable

Windows



Royal Dormers		
Shed Style windows not included	8' Shed	\$3,022
	12' Shed	\$4,008
	16' Shed	\$4,894
	20' Shed	\$5,880
	24' Shed	\$7,166
Peak Style window not included	14' Peak	\$3,126
	16' Peak	\$3,744
	Dog House	\$3,126
Transom Style 29" x 10" white insulated transoms included	Three	\$2,350
	Four	\$2,938
	Five	\$3,508
	Six	\$4,105
Farmhouse Dormer 24" x 24" white insulated windows included	Three	\$2,626
	Four	\$3,312
	Five	\$3,998
	Six	\$4,684

Single Hung Insulated Windows		
Available with or without grids	White Frame	Black Frame
24" x 36" Single Hung	\$500	\$855
30" x 36" Single Hung	\$560	\$975
30" x 40" Single Hung	\$600	\$1,025
30" x 54" Single Hung	\$680	\$1,155
40" x 54" Single Hung *Egress*	\$775	\$1,265

Insulated Transom Windows		
Available with or without grids	White Frame	Black Frame
29" x 12" Transom	\$345	\$595
35" x 12" Transom	\$385	\$645
24" x 24" Transom	\$315	\$495
36" x 36" Transom	\$425	\$695

Egress Insulated Windows		
Available with or without grids	White Frame	Black Frame
40" x 54" Single Hung *Egress*	\$775	\$1,265
36" x 36" Casement *Egress*	\$1,165	\$1,915

Residential building codes require a secondary means of escape in every sleeping room or living area. *You will need to add either an additional door or a 40"x54" or 36"x36" window as your emergency egress.*



Porch Overhang			
Length	8' Wide	10' Wide	12' Wide
16'	\$7,757	\$8,182	\$8,924
18'	\$7,325	\$8,772	\$9,577
20'	\$8,889	\$9,359	\$10,227
22'	\$9,450	\$9,941	\$10,871
24'	\$10,007	\$10,520	\$11,512
26'	\$10,559	\$11,094	\$12,148
28'	\$11,108	\$11,663	\$12,780

Includes 6" x 6" pressure treated posts, miratec trim, architectural shingles and on site assembly within 25 miles.

Overhang can not be added below a dormer.



Kick Starter

Cupolas and Weathervanes
shown on pages 90-91

Options

Doors

Insulated Hinged House Door	
3'w x 6'8"t Single Door	\$668
6" Transom window insert	\$90
10" Transom window insert	\$148
Half glass insert square	\$130
Half glass insert round	\$130
Full glass insert square	\$165
Full glass insert arched	\$295
Paint door	\$290
Stain door (espresso)	\$1,100

Sliding Glass Patio Door	
6' wide x 6'8" tall insulated	
White exterior, white interior	\$1,450
Black exterior, white interior	\$1,950
Black exterior, black interior	\$2,550



Timber Frame Accents

Constructed with Eastern White Pine
and pre-stained Espresso
Victorian Z-style shutters can be upgraded to pine
+\$25 per set



Available on Royal Victorian models with 10:12 Roof Pitch
Single Wide One Story Aframe and Double Wide Two Story Aframe

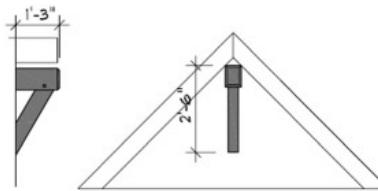

Corbel "A" \$300
(no vents when corbels are installed)

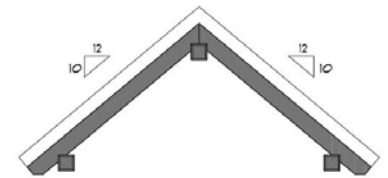

Show Rafters with Corbels "J" \$1,300
(no vents when corbels are installed)

Available on Royal Victorian models with 12:12 Roof Pitch
Single Wide Two Story Aframe

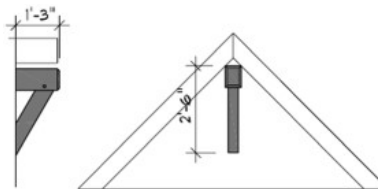

Corbel "A" \$300
(no vents when corbels are installed)

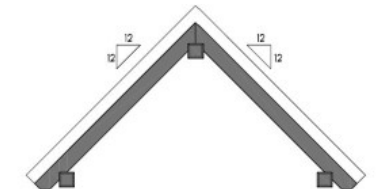

Show Rafters with Corbels "T" \$1,300
(no vents when corbels are installed)

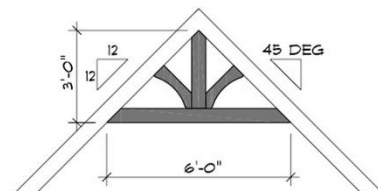

Straight Accent Truss "H" \$1,300

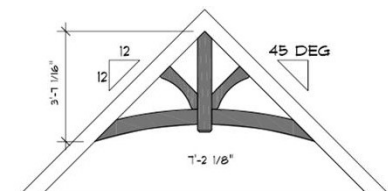

Arch Accent Truss "G" \$1,400

Modern Eyebrow Roof

Available on all Royal Victorian Models

Can only be installed on walls that are 10' or higher.

*INCLUDES 1X8 T&G PINE DECKING

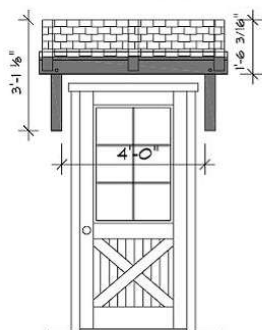

4' Eyebrow Roof "K" \$1,500
(for a 3' door)

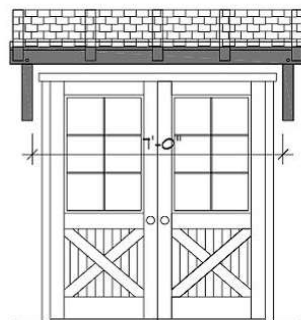

7' Eyebrow Roof "L" \$1,800
(for a 6' door)

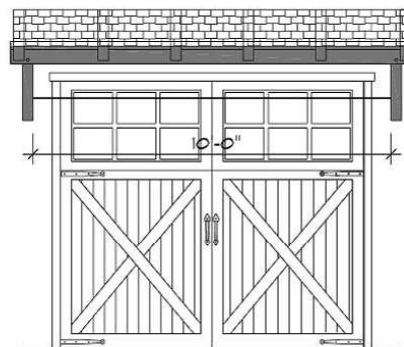

10' Eyebrow Roof "M" \$2,200
(for a garage door)

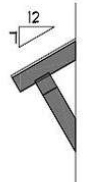

SIDE VIEW
ALL SIZES

Site Selection and Preparation

ACCESSIBILITY

Our truck and trailer need plenty of space to maneuver the building onto the pad. The direction from which we access your pad affects how we construct and load the building. This must be established at the time of ordering.

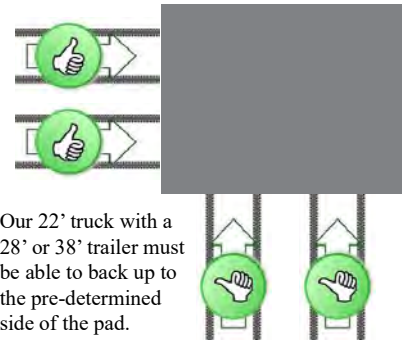

Our 22' truck with a 28' or 38' trailer must be able to back up to the pre-determined side of the pad.

APPROACH

The ground must be dry and solid and the entire approach must be clear of obstacles.



Above: We need at least 13'6" clearance, and even more space above the pad where the trailer will tilt up to off load the shed. Check for overhead wires, house eaves, branches and other obstacles.



Sides: We need the width of your shed plus one foot on each side. The approach and site must be clear from the road all the way to your site. Check for branches, bushes, fencing, play grounds, etc.



Below: The ground (driveway and/or lawn) must be hard enough for us to drive on with a heavy truck, trailer and shed. We will leave ruts and/or get stuck if it is not. We can not drive over any type of septic system, mound system, leach field, etc.



Abutting Property: We can not drive across your neighbor's property without their written permission. Ask us for a liability waiver if needed.

CONCRETE PAD

Your building includes a permanent wooden floor, however it will need to sit on a concrete pad to prevent movement or settling of the building. We recommend an Alaskan slab (or monolithic slab) reinforced with rebar and fiber mesh.

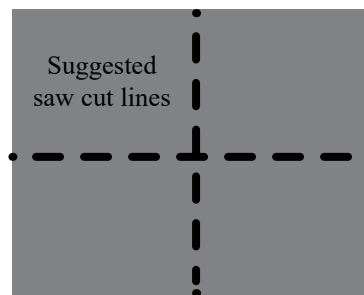

Please Note:

Your concrete pad must be perfectly level. Because of the design of our buildings and the delivery process, your concrete slab can NOT have a floor drain or have *anything* (anchor bolts, toe kick, pipes, etc.) protruding up from the floor.

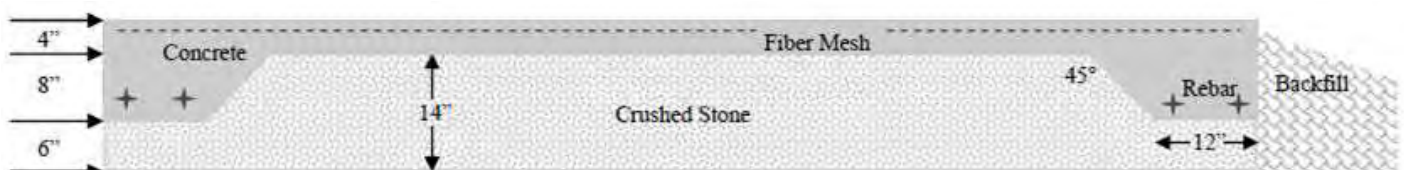

Delivery and Assembly Process

DELIVERY

The bottom portion will arrive to your site assembled with all of the pieces for the rest of the assembly inside.



ASSEMBLY

The assembly crew will install rafters, plywood sheathing, roofing, trim, vents, dormers and/or overhangs.



THINGS TO KNOW

- ~ Double wide structures (more than 14' wide) have permanent partial support walls where the two halves of the structure meet and attach.
- ~ Our structures come with a permanent wooden floor and 4" runners below. This raises the floor off the ground 9"-10", therefore a ramp or step may be needed for entry.
- ~ Delivery and assembly do not happen on the same day.
- ~ Building style, size, features, and weather all affect the assembly time line, typically a 3-15 day process.



Accessory



14' x 20' shown

Accessory Building - 2" x 4" Construction					
Square Feet	Width x Length	Colonial Lean To Studio	Colonial Aframe 7' Sidewall	Victorian Aframe 6' Sidewall	Victorian Aframe 7' Sidewall
140	10' x 14'	\$14,885	\$13,874	\$14,081	\$14,322
160	10' x 16'	\$16,176	\$15,105	\$15,320	\$15,559
180	10' x 18'	\$17,510	\$16,238	\$16,461	\$16,703
192	12' x 16'	\$17,848	\$16,777	\$16,858	\$17,280
200	10' x 20'	\$18,856	\$17,524	\$17,748	\$17,989
216	12' x 18'	\$19,288	\$18,016	\$18,110	\$18,533
224	14' x 16'	\$19,475	\$18,404	n/a	n/a
240	12' x 20'	\$20,678	\$19,346	\$19,484	\$19,866
252	14' x 18'	\$21,845	\$20,573	n/a	n/a
280	14' x 20'	\$23,524	\$22,192	n/a	n/a
288	12' x 24'	\$24,653	\$23,011	\$23,124	\$23,547
308	14' x 22'	\$25,165	\$23,583	n/a	n/a
336	12' x 28'	\$27,647	\$25,695	\$26,185	\$26,651
336	14' x 24'	\$26,857	\$25,047	n/a	n/a
364	14' x 26'	\$28,434	\$26,655	n/a	n/a
392	14' x 28'	\$30,264	\$28,312	n/a	n/a

Accessory Ready To

Standard Features on 2" x 4" Construction:

- LP Engineered Wood Siding with Miratec Trim
- 2" x 4" Wall Studs 16" On Center
- Fiberglass insulation in walls (R13)
- Wood paneling interior walls and ceiling, painted white
- Insulated, vented ceiling
- 2"x6" rafters 16" on center on Aframes
- 2" x 8" rafters 12" on center on Lean To Studio
- 30 year Architectural Shingles over tar paper
- Luxury Vinyl Flooring
- Pressure Treated Runners
- 2" x 4" Floor Joists 16" on center
- 2" spray foam insulation (R14) in floor
- One white 3' insulated door
- 24" x 36" insulated windows (U Factor 0.49) with Z-style shutters
 - < 250 sq ft = two white frame windows
 - > 250 sq ft = four white frame windows
- Electrical Package
 - < 250 sq ft = 100 amp sub breaker box, one light switch with one light mount, two interior outlet receptacles
 - > 250 sq ft = 100 amp main breaker box, one light switch with two light mounts, four interior outlet receptacles

FREE DELIVERY
within 50 miles!
All buildings are customizable.

~ Home Office ~ Backyard Studio ~ Workshop ~ Home Gym ~ Me Shed ~



10' x 14' shown



10' x 20' shown



12' x 16' shown

Buildings



14' x 20' shown

Buildings Customize

Standard Features on 2" x 6" Construction:

- LP Engineered Wood Siding with Miratec Trim
- 2" x 6" Wall Studs 16" On Center
- Fiberglass insulation in walls (R21)
- Wood paneling interior walls and ceiling, painted white
- Insulated, vented ceiling
- 2"x6" rafters 16" on center on Aframes
- 2" x 8" rafters 12" on center on Lean To Studio
- 30 year Architectural Shingles over tar paper
- Luxury Vinyl Flooring
- Pressure Treated Runners
- 2" x 6" Floor Joists 16" on center
- 3" spray foam insulation (R21) in floor
- One white 3' insulated door
- 24" x 36" insulated windows (U Factor 0.49) with Z-style shutters
 - < 250 sq ft = two white frame windows
 - > 250 sq ft = four white frame windows
- Electrical Package
 - < 250 sq ft = 100 amp sub breaker box, one light switch with one light mount, two interior outlet receptacles
 - > 250 sq ft = 100 amp main breaker box, one light switch with two light mounts, four interior outlet receptacles

Accessory Building - 2" x 6" Construction					
Square Feet	Width x Length	Colonial Lean To Studio	Colonial Aframe 7' Sidewall	Victorian Aframe 6' Sidewall	Victorian Aframe 7' Sidewall
140	10' x 14'	\$16,151	\$15,140	\$15,347	\$15,588
160	10' x 16'	\$17,580	\$16,509	\$16,724	\$16,963
180	10' x 18'	\$19,052	\$17,780	\$18,003	\$18,245
192	12' x 16'	\$19,408	\$18,337	\$18,418	\$18,840
200	10' x 20'	\$20,536	\$19,204	\$19,428	\$19,669
216	12' x 18'	\$20,998	\$19,726	\$19,820	\$20,243
224	14' x 16'	\$21,191	\$20,120	n/a	n/a
240	12' x 20'	\$22,538	\$21,206	\$21,344	\$21,726
252	14' x 18'	\$23,723	\$22,451	n/a	n/a
280	14' x 20'	\$25,564	\$24,232	n/a	n/a
288	12' x 24'	\$26,813	\$25,025	\$25,284	\$25,707
308	14' x 22'	\$27,367	\$25,785	n/a	n/a
336	12' x 28'	\$30,107	\$28,155	\$28,645	\$29,111
336	14' x 24'	\$29,221	\$27,411	n/a	n/a
364	14' x 26'	\$30,960	\$29,181	n/a	n/a
392	14' x 28'	\$32,952	\$31,000	n/a	n/a

Customizable Options

Electrical Add Ons	
Interior outlet receptacle (not near water)	\$85
GFI Outlet receptacle (exterior or near water source)	\$100
Light mount with switch	\$170
3-Way light set-up 1 light mount with 2 switches 2 light mounts with 1 switch	\$300

Floor Upgrades	
Spray Foam in floor 1" thicker	\$3/sq ft
2" x 4" Joists to 12" OC	\$1/sq ft
2" x 6" Joists to 12" OC	\$1.25/sq ft

Kinro Insulated Windows	White Grids	Clay Grids	Black Grids
24" x 36"	\$281	\$311	\$567
24" x 48"	n/a	n/a	\$647
30" x 36"	\$323	\$363	\$587
30" x 40"	\$362	\$403	n/a
30" x 54"	\$466	\$518	n/a
29"x10" Transom	\$225	\$250	\$275
U Factor	0.49	0.49	0.30

For windows that meet residential codes use the [Kick Starter](#) options on page 64.

Dormers are shown on page 106.
Prices listed include uninsulated windows.

Insulated Hinged House Door	
3'w x 6'8"t Single Door	\$668
6" Transom window insert	\$90
10" Transom window insert	\$148
Half glass insert square or round	\$130
Full glass insert square	\$165
Full glass insert arched	\$295
Paint door	\$290
Stain door (espresso)	\$1,100

Sliding Glass Patio Door 6'w x 6'8"t	
White exterior, white interior	\$1,450
Black exterior, white interior	\$1,950
Black exterior, black interior	\$2,550



Garage & Shed Design Guide

STEP 1

Select a Size

Things to consider when selecting the right size:

- What will you use it for?
- Will there be seasonal items stored?
- How can you maximize the wall space?
- How can you maximize the overhead space?

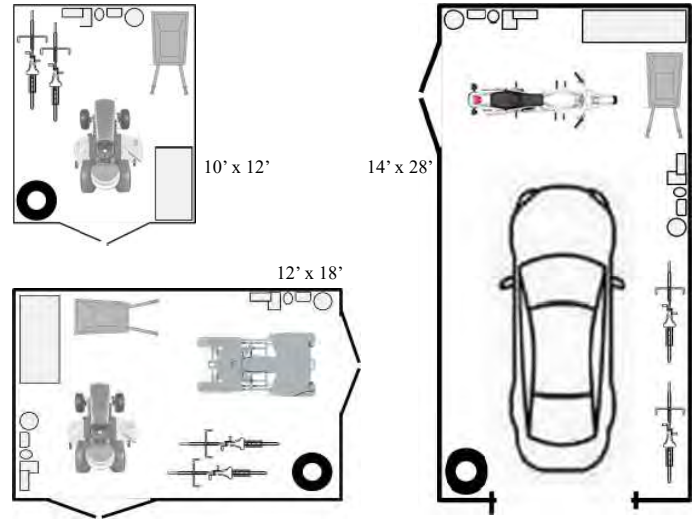

STEP 2

Choose Your Style

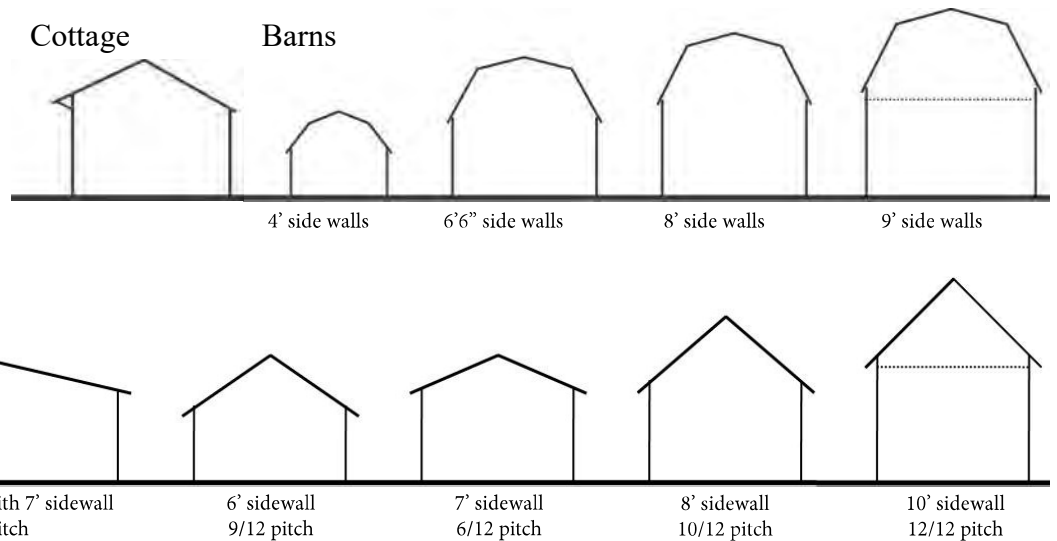

STEP 3

Trim Package, Doors and Windows

TRIM PACKAGE	Trim Style	Roof Overhang	Trim on Door	Trim Around Door	Hinges	Window Size	Window Trim	Shutters
CLASSIC	Metal	3"	Perma	None	Standard	18"x27"	None	Louvered
COLONIAL	Miratec	6"	Miratec	None	Standard	18"x27"	Miratec	Z-style
VICTORIAN	Miratec	12"	Miratec	Miratec	Victorian	24"x36"	Miratec	Z-style

STEP 4

Customize the Colors

Choose the type, then choose the color for your siding, trim and roofing (Options shown on pages 110 and 111)

Royal Two Story



24' x 24' shown

Two Story Double Wide Royal Victorian Dutch Barn

Standard Features:

- LP Engineered Wood Siding
- 2" x 4" Wall Studs 16" On Center
- 1" x 4" Miratec Trim
- Victorian Hinges
- 30 year Architectural Shingles
- Two Victorian Vents
- 2" x 6" Rafters 16" On Center
- 12" Roof Overhang on Gable Ends
- Stairway to Full Upstairs Loft
- 6'w x 7'h Double Wood Door
- Standard Style garge door(s)
- Four 24" x 36" Windows
- Four Sets of Z-style Shutters
- Permanent Wood Floor
- Pressure Treated Runners
- 2" x 6" Floor Joists 12" On Center

FREE DELIVERY
and On Site Assembly
within 25 miles!

All garages are customizable.

See pages 78 - 79 and 105 -113 for more options.

Royal Victorian Two Story Double Wide DUTCH BARN			
Width x Length	OH Door Dimensions	9' Tall Side Walls	10' Tall Side Walls
16' x 20'	One 9' x 7'	\$48,205	\$49,213
16' x 24'	One 9' x 7'	\$53,967	\$55,087
18' x 24'	One 9' x 7'	\$57,582	\$58,758
18' x 28'	One 9' x 7'	\$63,293	\$64,581
20' x 20'	Two 8' x 6'6"	\$66,153	\$67,273
20' x 24'	Two 8' x 6'6"	\$72,310	\$73,542
20' x 28'	Two 8' x 6'6"	\$78,166	\$79,510
24' x 24'	Two 9' x 7'	\$79,322	\$80,665
24' x 28'	Two 9' x 7'	\$86,062	\$87,518
24' x 30'	Two 9' x 7'	\$89,083	\$90,595
24' x 32'	Two 9' x 7'	\$91,161	\$92,729
28' x 28'	Two 9' x 7'	\$97,972	\$93,540
28' x 30'	Two 9' x 7'	\$96,236	\$97,860
28' x 32'	Two 9' x 7'	\$99,449	\$101,129

18' x 28' shown



16' x 20' shown



18' x 28' shown



Victorian

Double Wide



24' x 24' shown

Two Story Double Wide Royal Victorian

Aframe

Standard Features:

- LP Engineered Wood Siding
- 2" x 4" Wall Studs 16" On Center
- 1" x 4" Miratec Trim
- Victorian Hinges
- 30 year Architectural Shingles
- 10/12 Roof pitch
- Two Victorian Vents
- 2" x 8" Rafters 16" On Center
- 12" Roof Overhang
- Stairway to Full Upstairs Loft
- 6'w x 7'h Double Wood Door
- Standard Style garge door(s)
- Four 24" x 36" Windows
- Four Sets of Z-style Shutters
- Permanent Wood Floor
- Pressure Treated Runners
- 2" x 6" Floor Joists 12" On Center

FREE DELIVERY
and On Site Assembly
within 25 miles!

All garages are customizable.

See pages 78 - 79 and 105 -113 for more options.

Royal Victorian Two Story Double Wide AFRAME			
Width x Length	OH Door Dimensions	9' Tall Sidewall	10' Tall Sidewall
16' x 20'	One 9' x 7'	\$47,205	\$48,213
16' x 24'	One 9' x 7'	\$52,867	\$53,987
18' x 24'	One 9' x 7'	\$56,668	\$59,844
18' x 28'	One 9' x 7'	\$62,565	\$63,853
20' x 20'	Two 8' x 6'6"	\$64,869	\$65,989
20' x 24'	Two 8' x 6'6"	\$71,026	\$72,258
20' x 28'	Two 8' x 6'6"	\$76,882	\$78,226
24' x 24'	Two 9' x 7'	\$78,038	\$79,382
24' x 28'	Two 9' x 7'	\$84,778	\$86,234
24' x 30'	Two 9' x 7'	\$87,999	\$89,511
24' x 32'	Two 9' x 7'	\$90,077	\$91,645
28' x 28'	Two 9' x 7'	\$90,888	\$92,456
28' x 30'	Two 9' x 7'	\$94,953	\$96,577
28' x 32'	Two 9' x 7'	\$98,165	\$99,845

24' x 24' shown



26' x 24' shown



24' x 24' shown



Royal Two Story



14' x 28' shown

Two Story Single Wide Royal Victorian

Dutch Barn

Standard Features:

- LP Engineered Wood Siding
- 9' Sidewall
- 2" x 4" Wall Studs 16" On Center
- 1" x 4" Miratec Trim
- Victorian Hinges
- 30 year Architectural Shingles
- Two Victorian Vents
- 2" x 6" Rafters 16" On Center
- 12" Roof Overhang on Gable Ends
- Stairway to Full Upstairs Loft
- 6'w x 7'h Double Wood Door
- One 9'w x 7'h Standard Garage Door
- Four 24" x 36" Windows
- Four Sets of Z-style Shutters
- Permanent Wood Floor
- Pressure Treated Runners
- 2" x 6" Floor Joists 12" On Center

Royal Victorian Two Story Single Wide Dutch Barn	
12' x 16'	\$30,436
12' x 18'	\$32,274
12' x 20'	\$34,283
12' x 24'	\$38,139
12' x 28'	\$42,098
12' x 32'	\$46,237
14' x 20'	\$37,084
14' x 22'	\$39,051
14' x 24'	\$41,001
14' x 26'	\$43,095
14' x 28'	\$45,363
14' x 30'	\$47,692
14' x 32'	\$50,008

**FREE DELIVERY
and On Site Assembly
within 25 miles!**

All garages are customizable.

See pages 78 - 79 and 105 - 113 for more options.

14' x 28' shown



"The shed is absolutely beautiful and extremely well built! We love supporting local businesses and these guys are no exception. If you're on the market for a shed no matter how big or small, I highly recommend Livingston Farm!"

ERIC S. ~ VERGENNES, VT

Victorian

Single Wide



12' x 24' shown

Two Story Single Wide Royal Victorian

Aframe

Standard Features:

- LP Engineered Wood Siding
- 10' Sidewall
- 2" x 4" Wall Studs 16" On Center
- 1" x 4" Miratec Trim
- Victorian Hinges
- 30 year Architectural Shingles
- 10/12 Roof pitch
- Two Victorian Vents
- 2" x 8" Rafters 16" On Center
- 12" Roof Overhang
- Stairway to Full Upstairs Loft
- 6' w x 7' h Double Wood Door
- One 9' w x 7' h Standard Garage Door
- Four 24" x 36" Windows
- Four Sets of Z-style Shutters
- Permanent Wood Floor
- Pressure Treated Runners
- 2" x 6" Floor Joists 12" On Center

Royal Victorian Two Story Single Wide Aframe	
12' x 16'	\$30,169
12' x 18'	\$31,955
12' x 20'	\$33,915
12' x 24'	\$37,672
12' x 28'	\$41,531
12' x 32'	\$45,569
14' x 20'	\$36,737
14' x 22'	\$38,656
14' x 24'	\$40,556
14' x 26'	\$42,601
14' x 28'	\$44,817
14' x 30'	\$47,097
14' x 32'	\$49,364

FREE DELIVERY
and On Site Assembly
within 25 miles!

All garages are customizable.

See pages 78 - 79 and 105 - 113 for more options.



14' x 24' shown



14' x 24' shown



14' x 28' shown

Royal One Story



14' x 24' shown

One Story Single Wide Royal Victorian

Aframe & Dutch Barn

Standard Features:

- LP Engineered Wood Siding
- 2" x 4" Wall Studs 16" On Center
- 30 year Architectural Shingles
- 2" x 6" Rafters 16" On Center
- One Standard Garage Door
- Four 24" x 36" Windows
- Permanent Wood Floor
- 2" x 6" Floor Joists 12" On Center
- 1" x 4" Miratec Trim
- Victorian Hinges
- Two Victorian Vents
- 12" Roof Overhang on Gable Ends
- 6'w x 6'6"h Double Wood Door
- Four Sets of Z-style Shutters
- Pressure Treated Runners
- 10:12 Roof Pitch on Aframe



14' x 20' shown



14' x 24' shown

Royal Victorian One Story Single Wide Aframe		
Width x Length	Garage Door Dimensions	7'4" Tall Sidewall 2x4 Rafters
10' x 16'	8' x 6'6"	\$18,426
10' x 18'	8' x 6'6"	\$19,452
10' x 20'	8' x 6'6"	\$20,710
10' x 22'	8' x 6'6"	\$21,828
10' x 24'	8' x 6'6"	\$22,931
10' x 26'	8' x 6'6"	\$24,088
10' x 28'	8' x 6'6"	\$25,265
10' x 30'	8' x 6'6"	\$26,509
12' x 16'	9' x 7'	\$20,992
12' x 18'	9' x 7'	\$22,136
12' x 20'	9' x 7'	\$23,458
12' x 22'	9' x 7'	\$24,704
12' x 24'	9' x 7'	\$25,965
12' x 26'	9' x 7'	\$27,271
12' x 28'	9' x 7'	\$28,601
12' x 30'	9' x 7'	\$29,858
12' x 32'	9' x 7'	\$31,477

Royal Victorian One Story Single Wide		
Width x Length	8' Tall Sidewall 2x6 Rafters Includes one 9'w x 7't Garage Door	
	AFRAME	DUTCH BARN
12' x 16'	\$22,963	\$23,684
12' x 18'	\$24,133	\$24,945
12' x 20'	\$25,466	\$26,369
12' x 22'	\$26,840	\$27,829
12' x 24'	\$28,179	\$29,261
12' x 26'	\$29,597	\$30,769
12' x 28'	\$30,988	\$32,250
12' x 30'	\$32,339	\$34,071
12' x 32'	\$33,478	\$35,604
14' x 20'	\$27,268	\$28,172
14' x 22'	\$28,747	\$29,737
14' x 24'	\$30,192	\$31,275
14' x 26'	\$31,777	\$32,949
14' x 28'	\$33,528	\$34,790
14' x 30'	\$35,225	\$36,346
14' x 32'	\$36,887	\$38,328

FREE DELIVERY and
On Site Assembly within 25 miles!

All garages are customizable. See pages 78 - 79 and 105 - 113 for more options.

Victorian Single Wide



12' x 20' shown

One Story Single Wide Royal Victorian Lean To Studio

Standard Features:

- LP Engineered Wood Siding
- 1" x 4" Miratec Trim
- Pressure Treated Runners
- 2" x 6" Floor Joists 12" On Center
- Permanent Wood Floor
- 2" x 4" Studs 16" On Center
- 2" x 8" Rafters at 12" On Center
- 30 year Architectural Shingles
- Soffit Vents
- 12" Roof Overhang
- 6'w x 6'6"h Double Wood Door
- Victorian Hinges
- Two 24" x 36" Windows
- 33" x 33" Transoms at top of tall wall

Royal Victorian One Story Single Wide

Width x Length	LEAN TO STUDIO	# of transoms
10' x 16'	\$14,429	4
10' x 18'	\$15,213	4
10' x 20'	\$16,413	5
10' x 22'	\$17,518	5
10' x 24'	\$18,563	6
10' x 26'	\$19,709	6
10' x 28'	\$20,828	7
12' x 16'	\$16,508	4
12' x 18'	\$17,403	4
12' x 20'	\$18,668	5
12' x 22'	\$19,904	5
12' x 24'	\$21,108	6
12' x 26'	\$22,404	6
12' x 28'	\$23,678	7



12' x 22' shown



12' x 20' shown

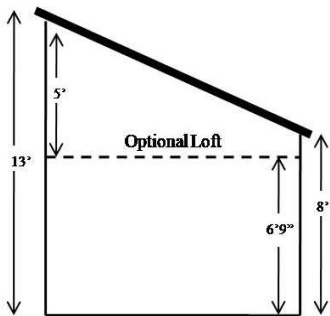

Measurements are approximate

2x8 Loft	10' Wide	12' Wide
4' long	\$800	\$1,000
6' long	\$1,100	\$1,300
8' long	\$1,300	\$1,500
10' long	\$1,500	\$1,700
12' long	\$1,700	\$1,900

FREE DELIVERY and On Site Assembly within 25 miles!

All garages are customizable. See pages 78 - 79 and 105 - 113 for more options.



Royal Victorian

Customizable Options



Royal Dormers		
Shed Style windows not included	8' Shed	\$2,950
	12' Shed	\$3,900
	16' Shed	\$4,750
	20' Shed	\$5,700
	24' Shed	\$6,950
Peak Style window not included	14' Peak	\$3,000
	16' Peak	\$3,600
	Dog House	\$3,000
Transom Style	Three	\$1,900
	Four	\$2,350
	Five	\$2,8000
	Six	\$3,250
Farmhouse Dormer 24" x 24" white uninsulated windows included	Three	\$2,050
	Four	\$2,550
	Five	\$3,050
	Six	\$3,550

Windows

Standard Shed Grade Windows				
Size	Set up	White Frame	Brown Frame	Black Frame
24" x 36"	4 over 4	\$155	\$155	\$171
24" x 36"	2 over 2	n/a	n/a	\$171
24" x 40"	4 over 4	\$163	\$163	\$180
24" x 48"	4 over 4	\$194	\$194	\$220
24" x 48"	2 over 2	n/a	n/a	\$220
30" x 36"	6 over 6	\$182	\$182	\$256
30" x 40"	6 over 6	\$219	\$219	n/a
30" x 54"	6 over 6	\$236	\$236	\$256
12" x 12"	4 lite	\$96	\$96	n/a
18" x 18"	4 lite	\$143	\$143	\$147
24" x 24"	4 lite	\$147	\$147	\$151
16" x 16"	Octagon	\$148	\$148	n/a
30" x 15"	Sunburst	\$145	\$145	n/a
10" Transom		\$105	\$105	\$130
Arch Trim over transom add \$45 per window				

Entry Level Insulated Windows				
Size	Grid Set up	White Frame	Clay Frame	Black Frame
24" x 36"	4 over 4	\$281	\$311	\$567
24" x 48"	4 over 4	n/a	n/a	\$647
30" x 36"	4 over 4	\$323	\$363	\$587
30" x 40"	4 over 4	\$362	\$403	n/a
30" x 54"	4 over 4	\$461	\$513	n/a
10" Transom		\$225	\$250	\$275



Porch Overhang			
Length	8' Wide	10' Wide	12' Wide
16'	\$7,757	\$8,182	\$8,508
18'	\$8,325	\$8,772	\$9,109
20'	\$8,889	\$9,359	\$9,707
22'	\$9,450	\$9,941	\$10,299
24'	\$10,559	\$10,520	\$10,888
26'	\$10,559	\$11,094	\$11,472
28'	\$11,108	\$11,663	\$12,052

Includes 6" x 6" pressure treated posts, miratec trim, architectural shingles and on site assembly within 25 miles.

Overhang can not be added below a dormer.



Cupolas and Weathervanes
shown on pages 90-91

Doors

Wooden Hinged Doors

Opening Width	6'6" high	7' high
3' Single	\$212	\$287
5' Double	\$254	\$330
5' Rounded Double	\$500	\$575
6' Double	\$268	\$343
8' Double	\$396	\$471
Arch Trim add \$40 per door		
Diamond Plate Threshold for wooden doors \$42		

House Doors

Opening Width	Fiberglass	Insulated
3' Single	\$354	\$668
5' Double	\$658	n/a
6' Double	\$696	n/a
Transom window insert	6" \$90	10" \$148
Half glass insert square	\$130	\$130
Half glass insert round	\$130	\$130
Full glass insert square	\$165	\$165
Full glass insert arched	\$295	\$295
Paint door	\$298/door	\$298/door
Stain door (espresso)	\$1,100/door	\$1,100/door
Sliding Patio Door 6'w x 6'8"t insulated	White exterior, white interior	\$1,450
	Black exterior, white interior	\$1,950
	Black exterior, black interior	\$2,550

Overhead Doors

Dimensions	Standard	Carriage
9' wide x 7' high	\$1,275	\$1,495
9' wide x 8' high	\$1,375	\$1,595
Insulated Overhead Door add \$250		
Painted overhead door add \$300 (red or black only) No charge colors include: White, Brown, Almond, Clay, Tan		
Diamond Plate Threshold for garage door \$72		

Timber Frame Accents



Made with Eastern White Pine
and pre-stained Espresso

Pine wood doors can be stained to match
timber frame accents +\$50 per door

Victorian Z-style shutters can be
upgraded to pine +\$25 per set

Available on Royal Victorian Aframe models with 10:12 Roof Pitch
Single Wide One Story and Double Wide Two Story

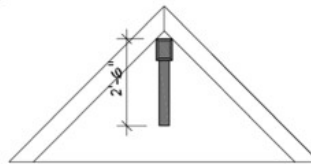

Corbel "A" \$300

(no vents when corbels are installed)

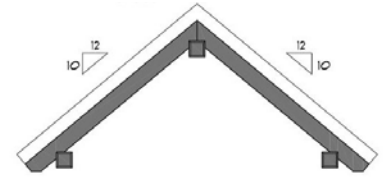

Show Rafters with Corbels "J" \$1,300

(no vents when corbels are installed)

Available on Royal Victorian Aframe models with 12:12 Roof Pitch
Single Wide Two Story

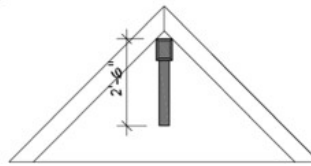

Corbel "A" \$300

(no vents when corbels are installed)

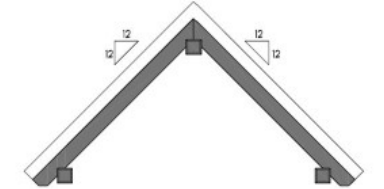

Show Rafters with Corbels "T" \$1,300

(no vents when corbels are installed)

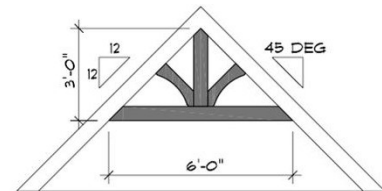

Straight Accent Truss "H" \$1,300

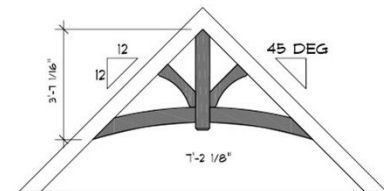

Arch Accent Truss "G" \$1,400

Modern Eyebrow Roof

Available on all Royal Victorian Models

Can only be installed on walls that are 10' or higher.

*INCLUDES 1X8 T&G PINE DECKING

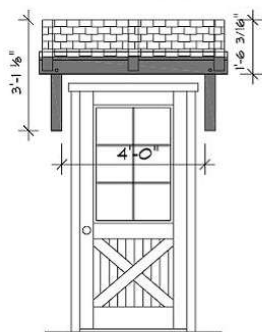

4' Eyebrow Roof "K" \$1,500
(for a 3' door)

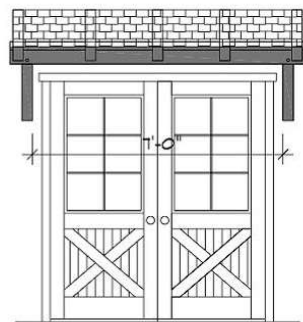

7' Eyebrow Roof "L" \$1,800
(for a 6' door)

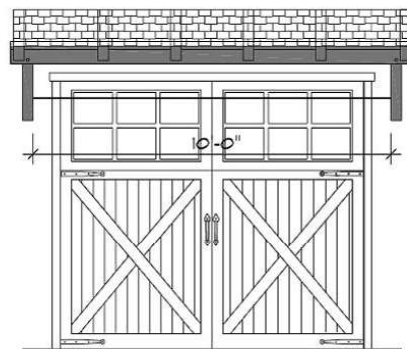

10' Eyebrow Roof "M" \$2,200
(for a garage door)

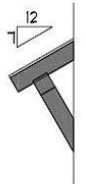

SIDE VIEW
ALL SIZES

Two Bay

Double Wide



24' x 24' shown

Two Bay One Story

Garage - 3:12 Pitch

Standard Features:

- LP Engineered Wood Siding
- Trim Style
 - Classic = Metal and Perma
 - Colonial = 1" x 4" Miratec Trim
- 7' Sidewall
- 2" x 4" Wall Studs 16" On Center
- Pressure Treated Runners
- 2" x 4" Floor Joists 12" on center
- Architectural Shingles
- 3:12 Roof Pitch
- Roof Overhang
 - Classic = 3"
 - Colonial = 6"
- Two Standard Garage Doors
- One 3' x 6' entry door
- Four 24" x 36" windows
- Four sets of Z-style shutters

FREE DELIVERY
and On Site Assembly
within 25 miles!

All garages are customizable.
See pages 105 - 113 for more options.

Double Wide Garage		3:12 Pitch	
Width x Length	OH Door Dimensions	Classic	Colonial
20' x 20'	8' x 6'6"	\$25,032	\$25,681
20' x 22'	8' x 6'6"	\$26,532	\$27,208
20' x 24'	8' x 6'6"	\$27,916	\$28,619
24' x 24'	9' x 7'	\$30,521	\$31,271
24' x 26'	9' x 7'	\$32,305	\$33,099
24' x 28'	9' x 7'	\$33,740	\$34,561
24' x 30'	9' x 7'	\$34,820	\$35,649
24' x 32'	9' x 7'	\$37,110	\$38,027
28' x 28'	9' x 7'	\$37,107	\$38,043
28' x 30'	9' x 7'	\$39,272	\$40,286
28' x 32'	9' x 7'	\$40,097	\$41,118



24' x 24' shown



24' x 28' shown



28' x 24' shown

Garage

Single Story



24' x 24' shown

Two Bay One Story

Garage - 5:12 Pitch

Double Wide Garage		5:12 Pitch
Width x Length	OH Door Dimensions	Colonial
24' x 20'	9' x 7'	\$34,779
24' x 22'	9' x 7'	\$36,481
24' x 24'	9' x 7'	\$37,995
24' x 26'	9' x 7'	\$40,599
24' x 28'	9' x 7'	\$42,376
24' x 30'	9' x 7'	\$43,661
24' x 32'	9' x 7'	\$46,941

Standard Features:

- LP Engineered Wood Siding
- Trim Style
 - Classic = Metal and Perma
 - Colonial = 1" x 4" Miratec Trim
- 8' Sidewall
- 2" x 4" Wall Studs 16" On Center
- Pressure Treated Runners
- 2" x 4" Floor Joists 12" on center
- Architectural Shingles
- 6:12 Roof Pitch
- Roof Overhang
 - Classic = 3"
 - Colonial = 6"
- Two Standard Garage Doors
- One 3' x 6' entry door
- Four 18" x 27" windows
- Four sets of Z-style shutters

FREE DELIVERY
and On Site Assembly
within 25 miles!

All garages are customizable.
See pages 105 - 113 for more options.



24' x 24' shown



24' x 24' shown



24' x 24' interior

One Bay Single Wide



12' x 24' shown

One Story Single Wide Garage

Aframes

Standard Features:

- LP Engineered Wood Siding
- Trim Style
 - Classic = Metal and Perma
 - Colonial = 1" x 4" Miratec Trim
 - Victorian = 1" x 4" Miratec Trim, Victorian Hinges and Two Victorian Vents
- 7' Sidewall
- 2" x 4" Wall Studs 16" On Center
- Pressure Treated Runners
- 2" x 4" Floor Joists 12" on center
- Architectural Shingles
- 3:12 Roof Pitch
- Roof Overhang
 - Classic = 3"
 - Colonial = 6"
 - Victorian = 12"
- One 9' x 7' Standard Garage Doors
- One 3' x 6' Single Wood Door
- Two Windows, with Shutters
 - Classic = 18" x 27", Louvered
 - Colonial = 18" x 27", Z-style
 - Victorian = 24" x 36", Z-style

FREE DELIVERY within 50 miles!

All garages are customizable.
See pages 83 -91 for more options.

Aframe	Classic	Colonial	Victorian
12x16	\$9,634	\$9,826	\$10,479
12x18	\$10,225	\$10,424	\$11,103
12x20	\$10,892	\$11,100	\$11,794
12x22	\$11,625	\$11,841	\$12,562
12x24	\$12,379	\$12,608	\$13,342
12x26	\$12,884	\$13,272	\$14,412
12x28	\$13,581	\$13,983	\$15,161
14x16	\$10,617	\$10,826	n/a
14x18	\$11,250	\$11,464	n/a
14x20	\$12,157	\$12,386	n/a
14x22	\$12,843	\$13,080	n/a
14x24	\$13,602	\$13,847	n/a
14x26	\$14,497	\$14,759	n/a
14x28	\$15,441	\$15,719	n/a
14x30	\$16,186	\$16,475	n/a
14x32	\$17,110	\$17,418	n/a

14' x 28' shown



14' x 28' shown



14' x 28' shown



Garage

Single Story



14' x 28' shown

One Story Single Wide Garage

Dutch Barns

Dutch Barn	Classic	Colonial	Victorian
12x16	\$9,519	\$9,774	\$10,112
12x18	\$10,111	\$10,370	\$10,732
12x20	\$10,746	\$11,017	\$11,403
12x22	\$11,694	\$11,980	\$12,390
12x24	\$12,273	\$12,566	\$13,000
12x26	\$12,884	\$13,340	\$13,798
12x28	\$13,581	\$14,051	\$14,533
14x16	\$10,617	\$10,894	\$11,264
14x18	\$11,250	\$11,532	\$11,930
14x20	\$12,157	\$12,454	\$12,880
14x22	\$12,843	\$13,148	\$13,602
14x24	\$13,602	\$13,915	\$14,397
14x26	\$14,497	\$14,827	\$15,337
14x28	\$15,441	\$15,787	\$16,325
14x30	\$16,186	\$16,543	\$17,109
14x32	\$17,113	\$17,486	\$18,080

Standard Features:

- LP Engineered Wood Siding
- Trim Style
 - Classic = Metal and Perma
 - Colonial = 1" x 4" Miratec Trim
 - Victorian = 1" x 4" Miratec Trim, Victorian Hinges and Two Victorian Vents
- 6'6" Sidewall
- 2" x 4" Wall Studs 16" On Center
- Pressure Treated Runners
- 2" x 4" Floor Joists 12" on center
- Architectural Shingles
- 3:12 Roof Pitch
- Roof Overhang on Gable Ends
 - Classic = 3"
 - Colonial = 6"
 - Victorian = 6"
- One 9' x 7' Standard Garage Doors
- One 3' x 6' Single Wood Door
- Two Windows, with Shutters
 - Classic = 18" x 27", Louvered
 - Colonial = 18" x 27", Z-style
 - Victorian = 24" x 36", Z-style

FREE DELIVERY within 50 miles!

All garages are customizable.

See pages 83 -91 for more options.



14' x 28' shown



"Livingston Farm was a pleasure to do business with. The shed we bought is great and they were outstanding delivering it and setting it up. Nothing was a problem for them and they were very precise and careful. I highly recommend them."

KAREN H. ~ HINESBURG, VT



12' x 24' shown

Studio Ridgeview



14' x 12' shown

FREE DELIVERY
within 50 miles!

All sheds are customizable.
See pages 105 - 113
for more options.



“The staff are knowledgeable, helpful, and awesome to work with and helped me design exactly what I had hoped for. The shed was built in under the quoted time, and the delivery couldn't have been smoother. These guys are total pros!”

DAN W. ~ SHELBURNE, VT

Ridgeview Studio

Standard Features:

- LP Engineered Wood Siding
- 1" x 4" Miratec Trim
- 2" x 4" Wall Studs 16" On Center
- Pressure Treated Runners
- 2" x 4" Floor Joists 16" on center
- Architectural Shingles
- Soffit Vents
- 2" x 8" Rafters 12" On Center
- 6" Roof Overhang
- Two 18" x 27" Windows
- Transom windows above split roof
- One Set of 6' Tall Double Doors
 - 8' - 16' length = 5' opening
 - 18' - 32' length = 6' opening

Ridgeview Studio		Transoms
8x10	\$5,915	2
8x12	\$6,550	2
8x14	\$7,082	2
8x16	\$7,760	2
8x18	\$8,215	2
10x10	\$7,161	3
10x12	\$7,850	3
10x14	\$8,457	3
10x16	\$9,180	3
10x18	\$9,741	3
12x10	\$7,990	3
12x12	\$8,766	3
12x14	\$9,425	3
12x16	\$10,256	3
12x18	\$10,867	3
14x10	\$8,837	4
14x12	\$9,665	4
14x14	\$10,526	4
14x16	\$11,387	4
14x18	\$12,024	4



14' x 16' shown



12' x 10' shown

Series

Lean To



14' x 20' shown

Lean-To Studio		Transoms
8x10	\$5,455	3
8x12	\$6,090	4
8x14	\$6,722	4
10x10	\$6,461	3
10x12	\$7,150	4
10x14	\$7,857	4
10x16	\$8,580	5
10x18	\$9,241	5
10x20	\$10,019	6
12x12	\$7,926	4
12x14	\$8,685	4
12x16	\$9,516	5
12x18	\$10,227	5
12x20	\$10,993	6
12x24	\$12,753	6
12x28	\$14,380	7
14x16	\$10,407	5
14x20	\$12,143	6
14x24	\$13,997	6
14x28	\$15,925	7
14x32	\$17,849	8

Lean To Studio

Standard Features:

- LP Engineered Wood Siding
- 1" x 4" Miratec Trim
- 2" x 4" Wall Studs 16" On Center
- Pressure Treated Runners
- 2" x 4" Floor Joists 16" on center
- Architectural Shingles
- Soffit Vents
- 2" x 8" Rafters 12" On Center
- 6" Roof Overhang
- Two 18" x 27" Windows
- Transom windows at top of tall wall
- One Set of 6' Tall Double Doors
 - 8' - 16' length = 5' opening
 - 18' - 32' length = 6' opening



10' x 12' shown

FREE DELIVERY
within 50 miles!

All sheds are customizable.

See pages 105 - 113 for more options.



12' x 20' shown



10' x 14' shown



14' x 20' shown

Victorian 7' Walls



12' x 20' shown

7' Sidewall

Victorian Aframes



8' x 12' shown

FREE DELIVERY
within 50 miles!

All sheds are customizable.

See pages 105 - 113 for more options.

Standard Features:

- 7' Sidewall
- LP Engineered Wood Siding
- 1" x 4" Miratec Trim
- 2" x 4" Wall Studs 16" On Center
- Pressure Treated Runners
- 2" x 4" Floor Joists 16" on center
- Architectural Shingles
- Two Victorian Vents
- 2" x 4" Rafters
- 12" Roof Overhang
- Two 24" x 36" Windows
- Two Sets of Z-style Shutters
- One Set of 6' Tall Double Doors
 - 8' - 16' length = 5' opening
 - 18' - 32' length = 6' opening

7' Walls Victorian Aframes

8x10	\$5,364
8x12	\$5,895
8x14	\$6,420
10x10	\$6,344
10x12	\$6,957
10x14	\$7,560
10x16	\$8,201
10x18	\$8,763
10x20	\$9,453
12x12	\$7,771
12x14	\$8,430
12x16	\$9,186
12x18	\$9,801
12x20	\$10,482
12x24	\$12,011
12x28	\$13,811

10' x 12' shown



10' x 16' shown



12' x 16' shown



Aframes

6' Walls



10' x 12' shown

6' Sidewall

Victorian Aframes

Standard Features:

- LP Engineered Wood Siding
- 1" x 4" Miratec Trim
- 2" x 4" Wall Studs 16" On Center
- Pressure Treated Runners
- 2" x 4" Floor Joists 16" on center
- Architectural Shingles
- Two Victorian Vents
- 2" x 4" Rafters
- 12" Roof Overhang
- Two 24" x 36" Windows
- Two Sets of Z-style Shutters
- One Set of 6' Tall Double Doors
 - 8' - 16' length = 5' opening
 - 18' - 32' length = 6' opening

6' Walls Victorian Aframes

6x8	\$4,353
8x8	\$4,639
8x10	\$5,164
8x12	\$5,716
8x14	\$6,237
10x10	\$6,102
10x12	\$6,715
10x14	\$7,319
10x16	\$7,962
10x18	\$8,521
10x20	\$9,212
12x12	\$7,348
12x14	\$8,009
12x16	\$8,764
12x18	\$9,378
12x20	\$10,100
12x24	\$11,588
12x28	\$13,345



12' x 10' shown

FREE DELIVERY
within 50 miles!

All sheds are customizable.

See pages 105 - 113 for more options.



10' x 16' shown



10' x 14' shown



8' x 10' shown

Aframe Colonial



14' x 20' shown



14' x 20' shown

7' Sidewall Colonial Aframes

Standard Features:

- 7' Sidewall
- LP Engineered Wood Siding
- 1" x 4" Miratec Trim
- 2" x 4" Wall Studs 16" On Center
- Pressure Treated Runners
- 2" x 4" Floor Joists 16" on center
- Architectural Shingles
- 2" x 4" Rafters
- 6" Roof Overhang
- Two 18" x 27" Windows
- Two Sets of Z-style Shutters
- One Set of 6' Tall Double Doors
 - 8' - 16' length = 5' opening
 - 18' - 32' length = 6' opening

7' Walls Colonial Aframes	
8x10	\$4,854
8x12	\$5,401
8x14	\$5,923
10x10	\$5,860
10x12	\$6,461
10x14	\$7,058
10x16	\$7,693
10x18	\$8,244
10x20	\$8,934
12x12	\$7,237
12x14	\$7,886
12x16	\$8,629
12x18	\$9,230
12x20	\$9,908
12x24	\$11,421
12x28	\$12,801
14x16	\$9,520
14x18	\$10,147
14x20	\$11,058
14x22	\$11,741
14x24	\$12,497
14x28	\$14,346

FREE DELIVERY within 50 miles!

All sheds are customizable.
See pages 105 - 113 for more options.



12' x 20' shown



10' x 16' shown



10' x 12' shown

Sheds

Classic



10' x 16' shown

6'6" Sidewall

Classic Aframes

Classic Aframes	
6x8	\$3,750
8x8	\$4,026
8x10	\$4,540
8x12	\$5,081
8x14	\$5,593
10x10	\$5,310
10x12	\$5,876
10x14	\$6,433
10x16	\$7,029
10x18	\$7,540
10x20	\$8,184
12x12	\$6,584
12x14	\$7,213
12x16	\$7,938
12x18	\$8,519
12x20	\$9,213
12x24	\$10,642
12x28	\$12,231

Standard Features:

- 6'6" Sidewall
- LP Engineered Wood Siding
- Metal trim on Corners
- Perma Trim on Doors
- 2" x 4" Wall Studs 16" On Center
- Pressure Treated Runners
- 2" x 4" Floor Joists 16" on center
- Architectural Shingles
- 2" x 4" Rafters
- 3" Roof Overhang
- Two 18" x 27" Windows
- Two Sets of Louvered Shutters
- One Set of 6' Tall Double Doors
 - 8' - 16' length = 5' opening
 - 18' - 32' length = 6' opening



8' x 10' shown

FREE DELIVERY within 50 miles!

All sheds are customizable.
See pages 105 - 113 for more options.

10' x 12' shown



10' x 14' shown



6' x 8' shown



Cottage

Oak Ridge



11' x 16' shown

Oak Ridge Cottage

Standard Features:

- Porch is part of the total width and runs the length of the building
- 4" x 4" Pressure treated posts on porch
- LP Engineered Wood Siding with 1" x 4" Miratec Trim
- 2" x 4" Wall Studs 16" On Center
- Pressure Treated Runners, 2" x 4" Floor Joists 16" on center
- Architectural Shingles, 2" x 4" Rafters
- 12" Roof Overhang on ends and front of building
- 3" Roof Overhang on back of building
- Two 24" x 36" Windows with Z-style Shutters
- One 6' Tall Single Door with Victorian Hinges
 - 2'6" door on 36" Porch
 - 3'0" door on 40" Porch

With 36" Porch	
11x12	\$7,609
11x14	\$8,389
11x16	\$9,178
11x18	\$9,920
11x20	\$10,698
11x22	\$11,468
11x24	\$12,291
11x26	\$13,043
11x28	\$13,784

With 40" Porch	
13x14	\$9,023
13x16	\$9,934
13x18	\$10,699
13x20	\$11,685
13x22	\$12,491
13x24	\$13,402
13x26	\$14,516
13x28	\$15,332
13x30	\$16,092

FREE DELIVERY within 50 miles!

All sheds are customizable.
See pages 105 - 113 for more options.



13' x 14' shown



11' x 12' shown



13' x 14' shown

Sheds

Victorian



10' x 16' shown

Victorian Cottage

Victorian Cottage		Victorian Cottage	
6x8	\$4,476	10x20	\$9,591
8x8	\$4,969	10x22	\$10,303
8x10	\$5,431	12x12	\$7,588
8x12	\$6,024	12x14	\$8,291
8x14	\$6,567	12x16	\$9,154
8x16	\$7,230	12x18	\$9,781
10x10	\$6,456	12x20	\$10,629
10x12	\$7,038	12x22	\$11,367
10x14	\$7,685	12x24	\$12,171
10x16	\$8,382	12x26	\$12,919
10x18	\$8,920	12x28	\$13,705

Standard Features:

- LP Engineered Wood Siding
- 1"x4" Miratec Trim
- Victorian Hinges
- Pressure Treated Floor System
- Floor Joists 16" on center
- 30 year Architectural Shingles
- Ridge Vent and two Victorian Vents
- 12" Roof Overhang
- Two 24" x 36" Windows
- Two sets of Z-style Shutters
- One set of 6' tall Double Doors
 - 8' - 16' length = 5' opening
 - 18' - 28' length = 6' opening



10' x 12' shown

FREE DELIVERY within 50 miles!

All sheds are customizable.
See pages 105 - 113 for more options.



12' x 20' shown



10' x 12' shown



10' x 16' shown

Cottage Colonial



10' x 16' shown



8' x 10' shown

Colonial Cottages

Standard Features:

- LP Engineered Wood Siding
- 1" x 4" Miratec Trim
- 2" x 4" Wall Studs 16" On Center
- Pressure Treated Runners
- 2" x 4" Floor Joists 16" on center
- Architectural Shingles
- 2" x 4" Rafters
- 6" Roof Overhang
- Two 18" x 27" Windows
- Two Sets of Z-style Shutters
- One Set of 6' Tall Double Doors
 - 8' - 16' length = 5' opening
 - 18' - 32' length = 6' opening

Colonial Cottage	
8x10	\$5,212
8x12	\$5,783
8x14	\$6,303
10x10	\$6,202
10x12	\$6,760
10x14	\$7,379
10x16	\$8,050
10x18	\$8,564
10x20	\$9,206
12x12	\$7,283
12x14	\$7,955
12x16	\$8,784
12x18	\$9,383
12x20	\$10,194
12x22	\$10,902
12x24	\$11,670
12x26	\$12,385
12x28	\$13,138

FREE DELIVERY within 50 miles!

All sheds are customizable.
See pages 105 - 113 for more options.



10' x 14' shown



12' x 20' shown



8' x 12' shown

Sheds

Classic



10' x 16' shown

Classic Cottages	
6x8	\$4,212
8x8	\$4,543
8x10	\$5,061
8x12	\$5,624
8x14	\$6,136
10x10	\$6,033
10x12	\$6,585
10x14	\$7,198
10x16	\$7,861
10x18	\$8,371
10x20	\$9,001
12x12	\$7,106
12x14	\$7,769
12x16	\$8,587
12x18	\$9,181
12x20	\$9,977
12x22	\$10,679
12x24	\$11,435

Classic Cottages

Standard Features:

- LP Engineered Wood Siding
- Metal trim on Corners
- Perma Trim on Doors
- 2" x 4" Wall Studs 16" On Center
- Pressure Treated Runners
- 2" x 4" Floor Joists 16" on center
- Architectural Shingles
- 2" x 4" Rafters
- 3" Roof Overhang
- Two 18" x 27" Windows
- Two Sets of Louvered Shutters
- One Set of 6' Tall Double Doors
 - 8' - 16' length = 5' opening
 - 18' - 32' length = 6' opening



10' x 12' shown

FREE DELIVERY within 50 miles!

All sheds are customizable.
See pages 105 - 113 for more options.



10' x 16' shown



12' x 24' shown



12' x 16' shown

Dutch Victorian



12' x 24' shown

Victorian Dutch Barn

Standard Features:

- 6" 6" Sidewall
- LP Engineered Wood Siding
- 1" x 4" Miratec Trim
- Victorian Hinges
- 2" x 4" Wall Studs 16" On Center
- Pressure Treated Runners
- 2" x 4" Floor Joists 16" on center
- Architectural Shingles
- 2" x 4" Rafters
- 6" Roof Overhang on Gable Ends
- Two 24" x 36" Windows
- Two Sets of Z-style Shutters
- One Set of 6' Tall Double Doors
 - 8' - 16' length = 5' opening
 - 18' - 32' length = 6' opening

FREE DELIVERY
within 50 miles!

All sheds are customizable.
See pages 105 - 113
for more options.

Victorian Dutch Barn	
8x10	\$5,079
8x12	\$5,663
8x14	\$6,127
8x16	\$6,806
10x10	\$6,005
10x12	\$6,579
10x14	\$7,280
10x16	\$7,924
10x18	\$8,624
10x20	\$9,214
10x22	\$9,933
12x12	\$7,559
12x14	\$8,147

Victorian Dutch Barn	
12x16	\$8,915
12x18	\$9,538
12x20	\$10,211
12x22	\$11,200
12x24	\$11,813
12x26	\$12,584
12x28	\$13,351
14x16	\$9,958
14x18	\$10,613
14x20	\$11,552
14x22	\$12,263
14x24	\$13,047
14x28	\$14,952



12' x 16' shown



10' x 12' shown

Barns

Colonial



12' x 16' shown

Colonial Dutch Barn

Colonial Dutch Barn		Colonial Dutch Barn	
8x10	\$4,785	12x16	\$8,413
8x12	\$5,353	12x18	\$9,000
8x14	\$5,801	12x20	\$9,637
8x16	\$6,464	12x22	\$10,590
10x10	\$5,531	12x24	\$11,167
10x12	\$6,053	12x26	\$11,902
10x14	\$6,702	12x28	\$12,633
10x16	\$7,294	14x16	\$9,520
10x18	\$7,942	14x18	\$10,147
10x20	\$8,480	14x20	\$11,058
10x22	\$9,147	14x22	\$11,741
12x12	\$7,129	14x24	\$12,497
12x14	\$7,681	14x28	\$14,346

Standard Features:

- 6'6" Sidewall
- LP Engineered Wood Siding
- 1" x 4" Miratec Trim
- 2" x 4" Wall Studs 16" On Center
- Pressure Treated Runners
- 2" x 4" Floor Joists 16" on center
- Architectural Shingles
- 2" x 4" Rafters
- 6" Roof Overhang on Gable Ends
- Two 18" x 27" Windows
- Two Sets of Z-style Shutters
- One Set of 6' Tall Double Doors
 - 8' - 16' length = 5' opening
 - 18' - 32' length = 6' opening

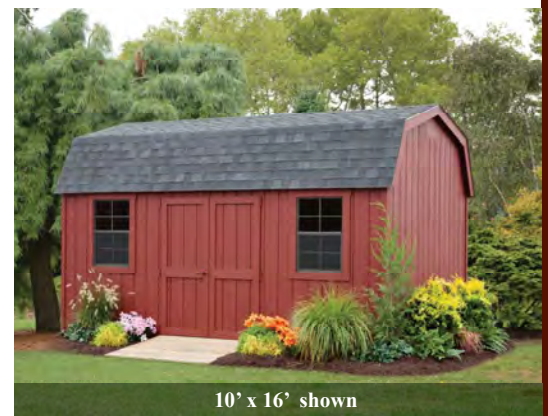

10' x 16' shown

FREE DELIVERY
within 50 miles!

All sheds are customizable.
See pages 105 - 113 for more options.



10' x 12' shown



12' x 18' shown



12' x 18' shown

Dutch Barn

Classic



10' x 16' shown



12' x 20' shown

Classic Dutch Barn

Standard Features:

- 6'6" Sidewall
- LP Engineered Wood Siding
- Metal trim on Corners
- Perma Trim on Doors
- 2" x 4" Wall Studs 16" On Center
- Pressure Treated Runners
- 2" x 4" Floor Joists 16" on center
- Architectural Shingles
- 2" x 4" Rafters
- 3" Roof Overhang
- Two 18" x 27" Windows
- Two Sets of Louvered Shutters
- One Set of 6' Tall Double Doors
 - 8' - 16' length = 5' opening
 - 18' - 32' length = 6' opening

Classic Dutch Barn	
8x10	\$4,648
8x12	\$5,208
8x14	\$5,650
8x16	\$6,304
10x10	\$5,381
10x12	\$5,896
10x14	\$6,536
10x16	\$7,121
10x18	\$7,758
10x20	\$8,290
10x22	\$8,948
12x12	\$6,953
12x14	\$7,503

Classic Dutch Barn	
12x16	\$8,226
12x18	\$8,809
12x20	\$9,434
12x22	\$10,372
12x24	\$10,942
12x28	\$12,231
14x16	\$9,311
14x18	\$9,933
14x20	\$10,829
14x22	\$11,504
14x24	\$12,252
14x26	\$13,135
14x28	\$14,068

FREE DELIVERY within 50 miles!

All sheds are customizable.
See pages 105 - 113 for more options.



12' x 20' shown



10' x 16' shown



8' x 12' shown

Hip Roof Victorian



12' x 18' shown

Victorian Hip Roof	
8x12	\$6,184
8x14	\$6,728
8x16	\$7,343
8x20	\$8,315
10x12	\$7,295
10x14	\$7,917
10x16	\$8,579
10x18	\$9,157
10x20	\$9,877
10x22	\$10,535
12x14	\$8,822
12x16	\$9,603
12x18	\$10,234
12x20	\$10,939
12x22	\$11,724
12x24	\$12,530
12x26	\$13,655
12x28	\$14,421

Victorian Hip Roof

Standard Features:

- LP Engineered Wood Siding
- 1" x 4" Miratec Trim
- Victorian Hinges
- 6'6" Sidewall
- 2" x 4" Wall Studs 16" On Center
- Pressure Treated Runners
- 2" x 4" Floor Joists 16" on center
- Architectural Shingles
- 2" x 4" Rafters
- 12" Roof Overhang
- Two 24" x 36" Windows
- Two Sets of Z-style Shutters
- One Set of 6' Tall Double Doors
 - 8' - 16' length = 5' opening
 - 18' - 32' length = 6' opening



12' x 20' shown

FREE DELIVERY within 50 miles!

All sheds are customizable.
See pages 105 - 113 for more options.



8' x 16' shown



8' x 14' shown



10' x 16' shown

Hip Roof Colonial



10' x 16' shown

Colonial Hip Roof

Standard Features:

- LP Engineered Wood Siding
- 1" x 4" Miratec Trim
- Victorian Hinges
- 6'6" Sidewall
- 2" x 4" Wall Studs 16" On Center
- Pressure Treated Runners
- 2" x 4" Floor Joists 16" on center
- Architectural Shingles
- 2" x 4" Rafters
- 6" Roof Overhang on Gable Ends
- Two 18" x 27" Windows
- Two Sets of Z-style Shutters
- One Set of 6' Tall Double Doors
 - 8' - 16' length = 5' opening
 - 18' - 32' length = 6' opening

FREE DELIVERY
within 50 miles!

All sheds are customizable.
See pages 105 - 113
for more options.

Colonial Hip Roof	
8x12	\$5,783
8x14	\$6,303
8x16	\$6,941
8x20	\$7,774
10x12	\$6,760
10x14	\$7,379
10x16	\$8,050
10x18	\$8,564
10x20	\$9,206
10x22	\$9,890
12x14	\$7,955
12x16	\$8,784
12x18	\$9,383
12x20	\$10,194
12x22	\$10,902
12x24	\$11,670
12x26	\$12,385
12x28	\$13,138



8' x 14' shown

★★★★★
"Great experience start to finish for a shed build and delivery. Staff was helpful going over options during the build process, and delivery process was smooth. High quality shed, and would recommend!"

PAUL V. ~ SHELBURNE, VT



8' x 12' shown

Sheds Classic



12' x 16' shown

Classic Hip Roof	
8x12	\$5,277
8x14	\$5,777
8x16	\$6,393
8x20	\$7,316
10x12	\$6,073
10x14	\$6,674
10x16	\$7,273
10x18	\$7,738
10x20	\$8,302
10x22	\$8,877
12x14	\$7,446
12x16	\$8,147
12x18	\$8,762
12x20	\$9,407
12x22	\$10,256
12x24	\$11,035
12x26	\$11,804
12x28	\$12,550

Classic Hip Roof

Standard Features:

- LP Engineered Wood Siding
- 1" x 4" Miratec Trim
- 6'6" Sidewall
- 2" x 4" Wall Studs 16" On Center
- Pressure Treated Runners
- 2" x 4" Floor Joists 16" on center
- Architectural Shingles
- 2" x 4" Rafters
- 3" Roof Overhang on Gable Ends
- Two 18" x 27" Windows
- Two Sets of Louvered Shutters
- One Set of 6' Tall Double Doors
 - 8' - 16' length = 5' opening
 - 18' - 32' length = 6' opening

FREE DELIVERY
within 50 miles!

All sheds are customizable.
See pages 105 - 113
for more options.



10' x 16' shown



10' x 20' shown

Farmhouse Victorian



12' x 20' shown

Farmhouse Finish Victorian

Standard Features:

- LP SmartPanel Siding
- 1" x 2" Miratec Battens at 12" OC
- 1" x 4" Miratec Trim
- Victorian Hinges
- 2" x 4" Wall Studs 12" On Center
- Pressure Treated Runners
- 2" x 4" Floor Joists 16" on center
- Architectural Shingles
- Two Victorian Vents
- 2" x 4" Rafters
- 12" Roof Overhang
- Two 24" x 36" Windows
- Two Sets of Z-style Shutters
- One Set of 6' Tall Double Doors
 - 8' - 16' length = 5' opening
 - 18' - 32' length = 6' opening

FREE DELIVERY
within 50 miles!

All sheds are customizable.
See pages 105 - 113
for more options.

VICTORIAN	Aframe 6' Walls	Aframe 7' Walls	Cottage	Dutch Barn
6x8	\$4,913	n/a	\$5,036	n/a
8x8	\$5,279	n/a	\$5,609	n/a
8x10	\$5,884	\$6,084	\$6,151	\$5,799
8x12	\$6,516	\$6,695	\$6,824	\$6,463
10x10	\$6,902	\$7,144	\$7,256	\$6,805
10x12	\$7,595	\$7,837	\$7,918	\$7,459
10x14	\$8,279	\$8,520	\$8,645	\$8,240
10x16	\$9,002	\$9,241	\$9,422	\$8,964
10x18	\$9,641	\$9,883	\$10,040	\$9,744
12x12	\$8,308	\$8,731	\$8,548	\$8,519
12x14	\$9,049	\$9,470	\$9,331	\$9,187
12x16	\$9,884	\$10,306	\$10,274	\$10,035
12x18	\$10,578	\$11,001	\$10,981	\$10,738
12x20	\$11,380	\$11,762	\$11,909	\$11,491
12x22	\$12,176	\$12,600	\$12,727	\$12,560
12x24	\$13,028	\$13,451	\$13,611	\$13,253
12x26	\$14,144	\$14,591	\$14,439	\$14,104
12x28	\$14,945	\$15,411	\$15,305	\$14,951



12' x 16' shown



12' x 18' shown



12' x 20' shown

Finish Colonial



12' x 16' shown

Farmhouse Finish Colonial

Standard Features:

- LP SmartPanel Siding
- 1" x 2" Miratec Battens at 12" OC
- 1" x 4" Miratec Trim
- 2" x 4" Wall Studs 12" On Center
- Pressure Treated Runners
- 2" x 4" Floor Joists 16" on center
- Architectural Shingles
- 2" x 4" Rafters
- 6" Roof Overhang
- Two 18" x 27" Windows
- Two Sets of Z-style Shutters
- One Set of 6' Tall Double Doors
 - 8' - 16' length = 5' opening
 - 18' - 32' length = 6' opening

FREE DELIVERY
within 50 miles!

All sheds are customizable.
See pages 105 - 113
for more options.

COLONIAL	Lean To Studio	Aframe 7' Walls	Cottage	Dutch Barn
8x10	\$6,175	\$5,574	\$5,932	\$5,505
8x12	\$6,890	\$6,201	\$6,583	\$6,153
10x10	\$7,261	\$6,803	\$7,002	\$6,331
10x12	\$8,030	\$7,341	\$7,640	\$6,933
10x14	\$8,817	\$8,561	\$8,339	\$7,662
10x16	\$9,620	\$8,733	\$9,090	\$8,334
10x18	\$10,361	\$9,364	\$9,684	\$9,062
12x12	\$8,886	\$8,197	\$8,243	\$8,089
12x14	\$9,725	\$8,923	\$8,995	\$8,721
12x16	\$10,636	\$9,749	\$9,904	\$9,533
12x18	\$11,427	\$10,430	\$10,583	\$10,200
12x20	\$12,273	\$11,188	\$11,474	\$10,917
12x24	\$14,193	\$12,861	\$13,110	\$12,607
12x28	\$15,980	\$14,401	\$14,738	\$14,233
14x16	\$11,607	\$10,702	n/a	\$10,720
14x20	\$13,503	\$12,418	n/a	\$12,418
14x24	\$15,517	\$14,017	n/a	14,017
14x28	\$17,605	\$16,026	n/a	\$16,026



10' x 16' shown



12' x 16' shown

Greenhouse



10' x 16' shown

Greenhouse

Standard Features:

- LP Engineered Wood Siding
- 1" x 4" Miratec Trim
- 7' Sidewall
- 2" x 4" Wall Studs 16" On Center
- Pressure Treated Runners
- Trex Flooring with scalloped bottom and hidden fasteners
- Metal Roof with clear polycarbonate on both sides of roof
- 2" x 4" Rafters
- 24" x 36" Windows
- One 3' Single Doors

FREE DELIVERY within 50 miles!

All sheds are customizable.
See pages 83 -91 for more options.

GREENHOUSE	Colonial Aframe	Victorian Aframe	# of windows
8x10	\$6,931	\$7,387	5
8x12	\$7,953	\$8,393	6
10x10	\$8,337	\$8,767	5
10x12	\$9,493	\$9,935	6
10x14	\$10,645	\$11,093	7
10x16	\$11,835	\$12,289	8
10x18	\$12,927	\$13,392	9
12x12	\$10,749	\$11,990	6
12x14	\$12,033	\$12,368	7
12x16	\$13,411	\$13,759	8
12x18	\$14,633	\$15,009	9
12x20	\$15,946	\$16,311	10
12x24	\$18,574	\$19,110	11
12x28	\$21,224	\$22,025	13

Customize your greenhouse:

- Plastic Grate Workbench
- 2' x 8' \$200
- 2' x 10' \$230
- 2' x 12' \$260
- 2' x 14' \$290

Farmhouse Finish Siding add \$20 per linear foot of wall
LP Board & Batten with 2x4 wall studs at 12" on center

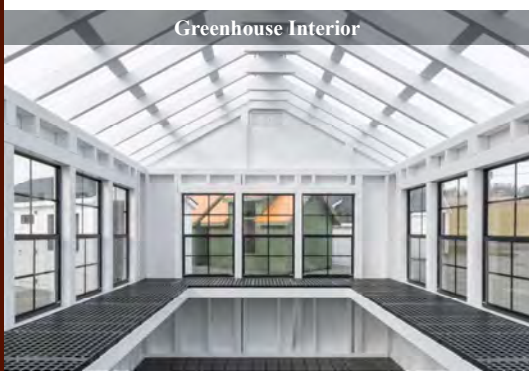

Greenhouse Interior



10' x 16' shown



10' x 14' shown

Firewood Storage



6' x 8' shown

Firewood Tall Wall

Standard Features:

- 30 year Architectural Shingles
- LP Engineered Wood Siding
- Pressure Treated Floor System
- Two Gable Vents
- Floor joists 16" on center

	Opening	Cords	Classic	Colonial	Victorian	
	6x8	6'	2	\$4,108	\$4,247	\$4,372
	8x8	6'	2 1/2	\$4,503	\$4,703	\$4,993
	8x10	8'	3	\$5,045	\$5,196	\$5,415
	8x12	8'	4	\$5,528	\$5,687	\$5,928
	Trim Style			Metal	Miratec	Miratec
	Roof Overhang			3"	6"	12"



8' x 8' shown



8' x 10' shown

Firewood Short Wall

Firewood Cottage

4x8	\$2,995
6x8	\$3,550

Standard

Features:

- LP Engineered Wood Siding
- 1" x 4" Miratec Trim
- Architectural Shingles
- Two Gable Vents
- Pressure Treated Floor System



4' x 8' shown



6' x 8' shown

FREE DELIVERY
within 50 miles!

Wood Shed Add-On

Attaches to the end of any shed
Pressure Treated Floor
Architectural Shingles

6' x 42" = \$1,698
8' x 42" = \$1,998



Storage Cube



8' x 12' shown



8' x 16' shown



8' x 12' shown

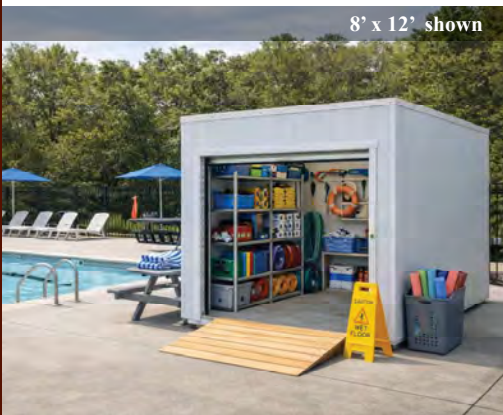

8' x 12' shown

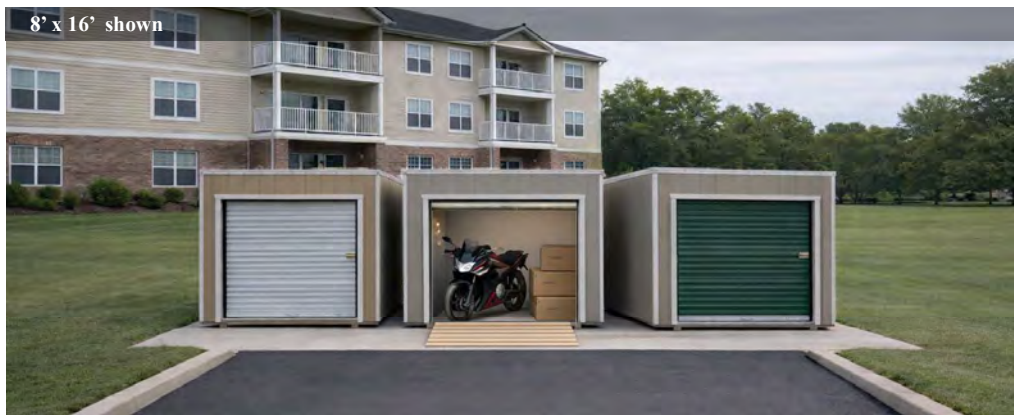

8' x 16' shown

Storage Units

Standard Features:

- 8'6" Sidewall
- LP Engineered Wood Siding
- Metal trim on corners of unit
- 2" x 4" Wall Studs 16" On Center
- Pressure Treated Runners
- 2" x 4" Floor joists at 12" On Center
- Seamless Aluminum Roof carbonate on both sides of roof
- One 6' x 6'6" Roll Up Door
- Perma trim around door

Storage Units	
8x12	\$6,258
8x16	\$7,556

FREE DELIVERY within 50 miles!

Customizable Options

SLAT WALL SYSTEM

4' x 8' Vinyl Slat Wall with Hook Package \$450
Add shelf and basket package \$150



RAMPS

Pressure Treated
Construction
6' \$175
8' \$200



PARTITIONS

8' wide \$368
10' wide \$378
12' wide \$388
14' wide \$398



WORKBENCHES AND LOFTS



Size	8' long	10' long	12' long	14' long
2' wide workbench	\$165	\$185	\$197	\$219
4' wide loft 2x4 joists	\$165	\$185	\$197	\$219
4' wide loft 2x6 joists	\$240	\$260	\$269	\$294
6' wide loft 2x4 joists	\$237	\$266	\$279	\$317
6' wide loft 2x6 joists	\$347	\$367	\$378	\$423



INTERIOR PAINT

Paint Interior Wall and Ceiling
\$2/sq ft of building foot print

Paint colors are shown on page 110



PORCH

The porch becomes
part of the overall
shed dimensions

Porch with pressure
treated decking
\$25 per square foot

Vinyl Railing \$295
per 4' section



Customizable Options

VENTS



Victorian Vent
\$33



8' Aluminum Ridge Vent
\$68



Gable Vent
\$25



Vinyl Vent
\$25

Soffit Vents installed on both long sides of building
\$14/linear foot of building length

BOOT RETURNS



Standard Boot Returns
\$72 per set



Shingled Boot Returns
\$178 per set

FLOORS

Floor Upgrades		
Pressure Treated Plywood		\$2/sq ft
Double Pressure Treated Plywood		\$4/sq ft
Upgrade floor joists from 16" to 12" on center		\$1/sq ft
Upgrade floor joists from 12" to 8" on center 8" on center not available with 2" x 6" floor joists		\$1/sq ft
Insulated, double pressure treated floor 5/8" plywood + 1/2" blueboard + 5/8" plywood (R4)		\$6/sq ft
Closed Cell Spray Foam 2" thick (R14)		\$7/sq ft
Closed Cell Spray Foam 3" thick (R21)		\$10/sq ft
Closed Cell Spray Foam 4" thick (R28) Only available Royal Victorians with 2x6 floor joists		\$13/sq ft
Black Rubberized Floor 3/4" Double coated, painted edges, OSB		\$4/sq ft
Silver LuxGuard Rubber Flooring Textured rubber with fiberglass backing. Impermeable, durable, slip resistant, strong.	10' wide	\$32/lin ft
	12' wide	\$34/lin ft
	14' wide	\$37/lin ft

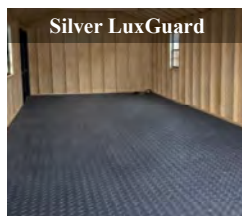

SHED DORMERS

Transom Dormer

Double \$525

Triple \$725

Quadruple \$925



Farmhouse Dormer

Only available on the
Victorian Aframe with 6' sidewall

18" x 18" Windows
set above the roofline
Double \$600
Triple \$840
Quadruple \$1,085
Quintuple \$1,325



24" x 24" Windows
no roof below dormer
Double \$610
Triple \$850
Quadruple \$1,100
Quintuple \$1,350

Peak Dormer

Standard Peak
\$800

Peak Dormer with
16" Bump Out
\$1,350

(bumpout cannot be added
to a 14' wide building)



TIMBER FRAME ACCENTS

Constructed with Eastern White Pine and pre-stained Espresso

Pine wood doors stained to match timber frame accents +\$50 per door

Victorian Z-style shutters can be upgraded to pine +\$25 per set



Available on buildings with 6:12 Roof Pitch

Colonial Aframe and Victorian Aframe with 7' side walls

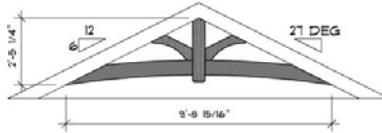

Arch Accent Truss "C" \$700

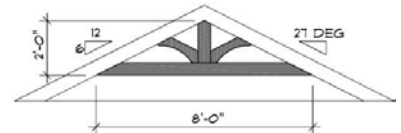

Straight Accent Truss "D" \$600

Available on buildings with 9:12 Roof Pitch

Victorian Aframe with 6' side walls

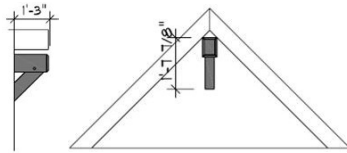

Corbel "B" \$250
(no vents when corbels are installed)

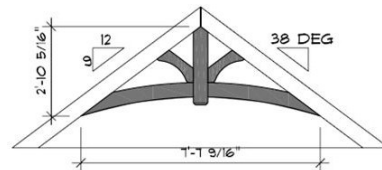

Arch Accent Truss "E" \$700

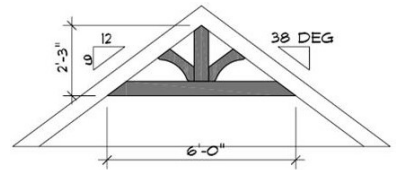

Straight Accent Truss "F" \$600

Modern Eyebrow Roof

Available preinstalled on gable end only on Colonial and Victorian Aframes with 7' sidewall

Includes 1x8 Tongue and Groove Pine Decking

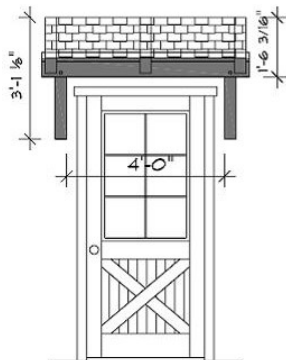

4' Eyebrow Roof "K" \$1,250
(for a 3' door)

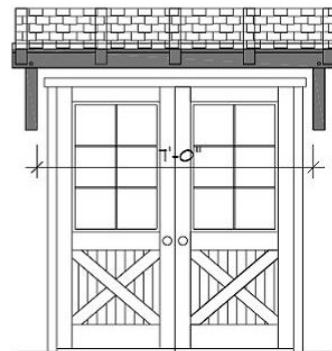

7' Eyebrow Roof "L" \$1,475
(for a 6' door on a 14' wide building)



SIDE VIEW
ALL SIZES



ALCOVE with Pine V-Groove Inlay

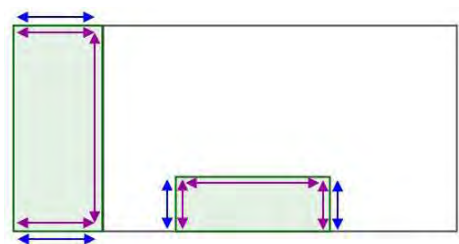

Pricing Formula

Step	Description	Price
Step 1	Add porch with pressure treated decking (Priced per square foot of porch area)	\$25/ sq ft
Step 2	Add the finished wall on porch ends (Priced per linear foot on each end wall)	\$55/ lin ft
Step 3	Add the pine v-groove accent wall (Priced per linear foot of each wall)	\$65/ lin ft

Customizable Options

WINDOWS

Standard Shed Windows				
Size	Grid set up	White Grids	Brown Grids	Black Grids
18" x 27"	4 over 4	\$128	\$128	\$145
24" x 36"	4 over 4	\$155	\$155	\$171
24" x 36"	2 over 2	n/a	n/a	\$171
24" x 40"	4 over 4	\$163	\$163	\$180
24" x 48"	4 over 4	\$194	\$194	\$220
24" x 48"	2 over 2	n/a	n/a	\$220
30" x 36"	6 over 6	\$182	\$182	\$206
30" x 40"	6 over 6	\$219	\$219	n/a
30" x 54"	6 over 6	\$236	\$236	\$256
12" x 12"	Square or Diamond	\$96	\$96	n/a
18" x 18"	4 lite	\$143	\$143	\$147
24" x 24"	4 lite	\$147	\$147	\$151
16" x 16"	Octagon	\$148	\$148	n/a
30" x 15"	Sunburst	\$145	\$145	n/a
10" Transom		\$105	\$105	\$130
Arch trim over transom add \$45 per window				

Kinro Insulated Windows				
Size	Grid set up	White Grids	Clay Grids	Black Grids
24" x 36"	4 over 4	\$281	\$311	\$567
24" x 48"	4 over 4	n/a	n/a	\$647
30" x 36"	4 over 4	\$323	\$363	\$587
30" x 40"	4 over 4	\$362	\$403	n/a
30" x 54"	4 over 4	\$466	\$518	n/a
10" Transom		\$225	\$250	\$275



24" x 24" Skylight Window with Solarlight \$275



Victorian Flowerbox \$58
Available in any of the duratemp paint colors



Vinyl Flowerbox \$58
Available in red, black, clay, dark blue, dark gray, cream, brown, green, white

Diamond or Square Window 12" x 12"



Octagon Window 16" x 16"



Sunburst Window 30" x 15"



Victorian Z-style Shutters \$50 per set



Raised Panel Shutters \$48 per set



Louvered Shutters \$48 per set

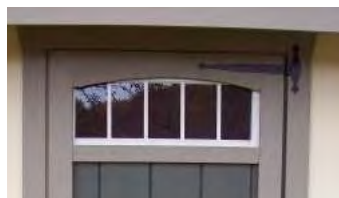

Transom Window with Arch Trim



10" High Transom Windows



Square Transom Window 18" x 18" or 24" x 24"



Wood Sash Window 28.5" x 41" \$225
42" x 52.5" \$335



Wood Sash Window with Arch Trim 28.5" x 41" \$265 each
42" x 52.5" \$375 each



Eye-brow Sash Windows \$442 per set of two

DOORS

<u>Wooden Hinged Doors</u>	6' high	7' high
3' Single	\$212	\$287
5' Double	\$254	\$330
5' Rounded Double	\$500	\$575
6' Double	\$268	\$343
8' Double	\$396	\$471
Arch Trim add \$40 per door		
Diamond Plate Threshold add \$40 per door		

Classic



3' Single



5' Double



6' Double

Colonial



3' Single shown with Arch Trim



5' Double shown with Transom Windows



6' Double

Victorian



5' Rounded Double



6' Double shown with Arched Transom Windows



8' Double

<u>Roll Doors</u>	6' high	7' high	8' high
4' opening single	\$575	n/a	n/a
6' opening double	\$1,095	\$1,245	n/a
8' opening double	\$1,125	\$1,275	\$1,475



4' Single Roll Door



8' Double Roll Doors shown with sash windows

<u>Sliding Patio Doors</u> 6' wide a 6'8" tall	
White exterior, white interior	\$1,450
Black exterior, white interior	\$1,950
Black exterior, black interior	\$2,550



<u>Hinged Doors</u>	Fiberglass	Insulated
3' Single	\$354	\$668
5' Double	\$658	n/a
6' Double	\$696	n/a
Transom window insert	6" \$90	10" \$148
Half square glass insert	\$130	\$130
Full square glass insert	\$165	\$165
Half round glass insert	\$130	\$130
Full round glass insert	\$295	\$295
Paint Door	\$290/door	\$290/door



3' shown with rounded half glass insert



6' shown with half arch full glass insert

<u>Overhead Doors</u>	Standard	Carriage
9'w x 7'h	\$1,275	\$1,495
9'w x 8'h	\$1,375	\$1,595
Insulated Overhead Door add \$250		
Painted Overhead Door add \$298 (Red or Black only)		
Standard (no charge) colors include: White, Brown, Almond, Tan, Clay		
Garage Door Diamond Plate Threshold \$72		

Standard Style



Carriage Style



Siding Options



LP Engineered Wood Siding (standard on all buildings)

Extra paint \$54/gallon



Vinyl Siding

Add 10% to base price



Specialty Siding

Percentage added to base price of building



LP Lap Siding +15%



Log Siding +50%



Cedar Shake +50%



Cedar Clapboard +50%



Pine Board & Batten +30%

Roofing Options

Architectural Shingles

(standard on all buildings)



Rustic Black



Weatherwood



Rustic Cedar



Virginia Slate



Old English Pewter



National Blue



Rustic
Evergreen



Rustic
Redwood



Metal Roof

Upgrade of \$6.00 per square foot of shed footprint

Metal roof with dormer add an additional \$125 per dormer



Bright White



Polar White



Light Stone



Ivory

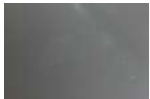

Clay



Tan



Ash Gray

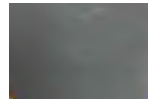

Pewter Gray



Charcoal



Burnished Slate



Copper Metallic



Brown



Burgundy



Rural Red



Bright Red



Evergreen



Ivy Green



Gallery Blue



Ocean Blue



Black



Cupolas

Shed Series

Includes vinyl base, metal top or copper top with staybrite applied and roof pitch cut out

CLASSIC

Vinyl Base	Copper Top
21"sq x 23"h	\$530
25"sq x 30"h	\$710
30"sq x 36"h	\$1,000

Vinyl Base	Metal Top
21"sq x 23"h	\$330
25"sq x 30"h	\$485
30"sq x 36"h	\$765



MANOR

Vinyl Base	Copper Top
21"sq x 23"h	\$662
25"sq x 30"h	\$850
30"sq x 36"h	\$1,125

Vinyl Base	Metal Top
21"sq x 23"h	\$460
25"sq x 30"h	\$615
30"sq x 36"h	\$930



ELITE

Vinyl Base	Copper Top
21"sq x 23"h	\$580
25"sq x 30"h	\$775
30"sq x 36"h	\$1,098



VICTORIAN

Vinyl Base	Copper Top
21"sq x 23"h	\$715
25"sq x 30"h	\$920
30"sq x 36"h	\$1,265



Royal Victorian Series

Includes vinyl base, copper top with staybrite applied and roof pitch cut out

CARLISLE

Vinyl Base	Copper Top
22"sq x 38"h	\$970
24"sq x 45"h	\$1,205
30"sq x 56"h	\$1,515
36"sq x 65"h	\$1,800
42"sq x 76"h	\$2,295
48"sq x 85"h	\$2,650



NORWOOD

Vinyl Base	Copper Top
22"sq x 38"h	\$970
24"sq x 46"h	\$1,205
30"sq x 59"h	\$1,515
36"sq x 68"h	\$1,800
42"sq x 80"h	\$2,295
48"sq x 89"h	\$2,650



BETHANY

Vinyl Base	Copper Top
24"sq x 48"h	\$1,235
30"sq x 60"h	\$1,665
36"sq x 69"h	\$2,050
42"sq x 80"h	\$2,585
48"sq x 91"h	\$3,025



CUPOLA OPTIONS

Size	Screens	Painted Vinyl	Copper Louvers	Colored Louvers
21" - 22"	\$44	\$99	\$197	\$54
24" - 25"	\$47	\$112	\$266	\$87
30"	\$58	\$128	\$348	\$102
36"	\$68	\$149	\$477	\$117
42"	\$77	\$168	\$640	\$131
48"	\$86	\$189	\$784	\$149

Louver and roof colors:
 - Black - Brown
 - Green - Blue
 - Red - Coppertone
 - Copper



Weather vanes

SHED SERIES

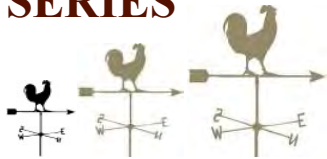

Horse \$108
17.5"L x 12.5"H



Rooster \$108
17.5"L x 12.5"H



Eagle \$108
17.5"L x 13.5"H

GARDEN SERIES

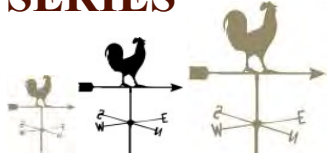

Motorcycle \$290
14"L x 9"H



Flying Pig \$250
12"L x 8"H
21" Long Arrow



Labrador Retriever \$230
13"L x 9"H
21" Long Arrow



Horse \$230
15"L x 10"H
21" Long Arrow



Sailboat \$240
10"L x 11.5"H
21" Long Arrow



Eagle \$335
12"L x 19"H x 16" Wingspan
21" Long Arrow



Rooster \$230
10"L x 11"H
21" Long Arrow



Wine Bottle \$280
9"L x 9"H x 3" W
Directionals: 11"L x 6.5"H



Victorian Arrow \$250
21"L x 17"H

STANDARD SERIES

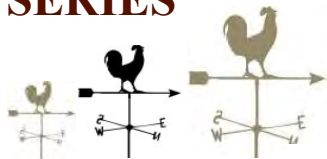

Arrow \$365
23"L x 15"H



American Flag \$410
31"L x 15"H



Proud Buck \$270
21"L x 17"H



Flying Pig \$510
24"L x 19"H x 12"W



Bass with Lure \$475
27"L x 12"H



Victorian Arrow \$415
32"L x 25"H



Eagle \$500
23"L x 20"H x 23" Wingspan



Horse \$530
33"L x 18"H x 4"W



Rooster \$475
26.5"L x 22"H

ESTATE SERIES

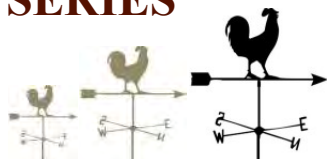

Horse on Arrow \$795
48"L x 23.5"H x 3"W



Barn Rooster \$845
37"L x 32"H



Large Sailboat \$570
28"L x 36"H x 3"W

All estate, standard and garden series weather vanes include assembly rod, spacer ball and directional set.

Apply Staybrite Lacquer to any copper weather vane for \$70

Measurements refer to weather vane figure only

Horse Barn

Stall & Feed Room



12' x 18' shown

Stall & Feed/Tack Room Combination

FREE DELIVERY
within 50 miles!

All barns are customizable.
See pages 110 - 113, 115
and 116 for more options.

Standard Features:

- Cottage Style Roof Line
- LP Engineered Wood Siding
- Architectural Shingles
- Ridge Vent
- Two Gable Vents
- Partition in Two-Part Barns
- Trim Style
 - Classic = Standard Metal
 - Colonial = 1" x 4" Miratec
- Overhang
 - Classic = 3"
 - Colonial = 6"
- Per Stall
 - No Floor
 - One 4' Dutch Door
 - Plywood to Square
- Per Feed Room
 - Pressure Treated Floor
 - One 3' Single Door

Stall and Feed/Tack Room Combo				
Size	Stalls	Feed Room	Classic	Colonial
8x10	1		\$5,347	\$5,467
8x12	1		\$5,922	\$6,052
8x14	1		\$6,489	\$6,628
8x16	1	1	\$7,611	\$7,763
8x18	1	1	\$8,057	\$8,265
8x20	1	1	\$8,539	\$8,700
10x10	1		\$6,345	\$6,486
10x12	1		\$6,950	\$7,099
10x14	1		\$7,575	\$7,733
10x16	1	1	\$8,776	\$8,946
10x18	1	1	\$9,288	\$9,513
10x20	2		\$9,886	\$10,074
10x22	2		\$10,575	\$10,774
12x12	1		\$7,476	\$7,629
12x14	1		\$8,196	\$8,360
12x16	1		\$9,032	\$9,210
12x18	1	1	\$10,155	\$10,392
12x20	2		\$10,880	\$11,083
12x22	2		\$11,640	\$11,854
12x24	2		\$12,415	\$12,644
12x26	2	1	\$13,380	\$13,614
12x28	2	1	\$14,101	\$14,345

12' x 18' shown



12' x 28' shown



Combination Stall & Run-In



12' x 20' shown

Stall & Run-In Combination

FREE DELIVERY within 50 miles!

All barns are customizable.
See pages 110 - 113, 115 and 116 for more options.

Stall / Run-In Combo		
	Classic	Colonial
8x16	\$7,577	\$7,729
8x18	\$8,023	\$8,181
8x20	\$8,505	\$8,665
10x16	\$8,742	\$8,912
10x18	\$9,304	\$9,479
10x20	\$9,993	\$10,181
10x22	\$10,682	\$10,881
12x18	\$10,121	\$10,308
12x20	\$10,987	\$11,190
12x22	\$11,747	\$11,961
12x24	\$12,522	\$12,751
12x26	\$13,007	\$13,241
12x28	\$13,728	\$13,972

Standard Features:

- Cottage Style Roof Line
- LP Engineered Wood Siding
- Architectural Shingles
- Ridge Vent
- Two Gable Vents
- Partition in Two-Part Barns
- Trim Style
 - Classic = Standard Metal
 - Colonial = 1" x 4" Miratec
- Overhang
 - Classic = 3"
 - Colonial = 6"
- Per Stall
 - No Floor
 - One 4' Dutch Door
 - Plywood to Square
- Per Run-In
 - No Floor
 - Plywood to Square

Horse Barn Overhang

Includes 6" x 6" pressure treated posts, miratec trim, architectural shingles, and on site assembly within 25 miles

Building Length	8' Wide Overhang	10' Wide Overhang	12' Wide Overhang
10'	\$6,028	\$6,384	\$6,938
12'	\$6,608	\$6,987	\$7,604
14'	\$7,184	\$7,587	\$8,266
16'	\$7,757	\$8,182	\$8,924
18'	\$8,325	\$8,772	\$9,577
20'	\$8,889	\$9,359	\$10,227
22'	\$9,450	\$9,941	\$10,871
24'	\$10,007	\$10,520	\$11,512
26'	\$10,559	\$11,094	\$12,148
28'	\$11,108	\$11,663	\$12,780



Horse Barn

Run-Ins

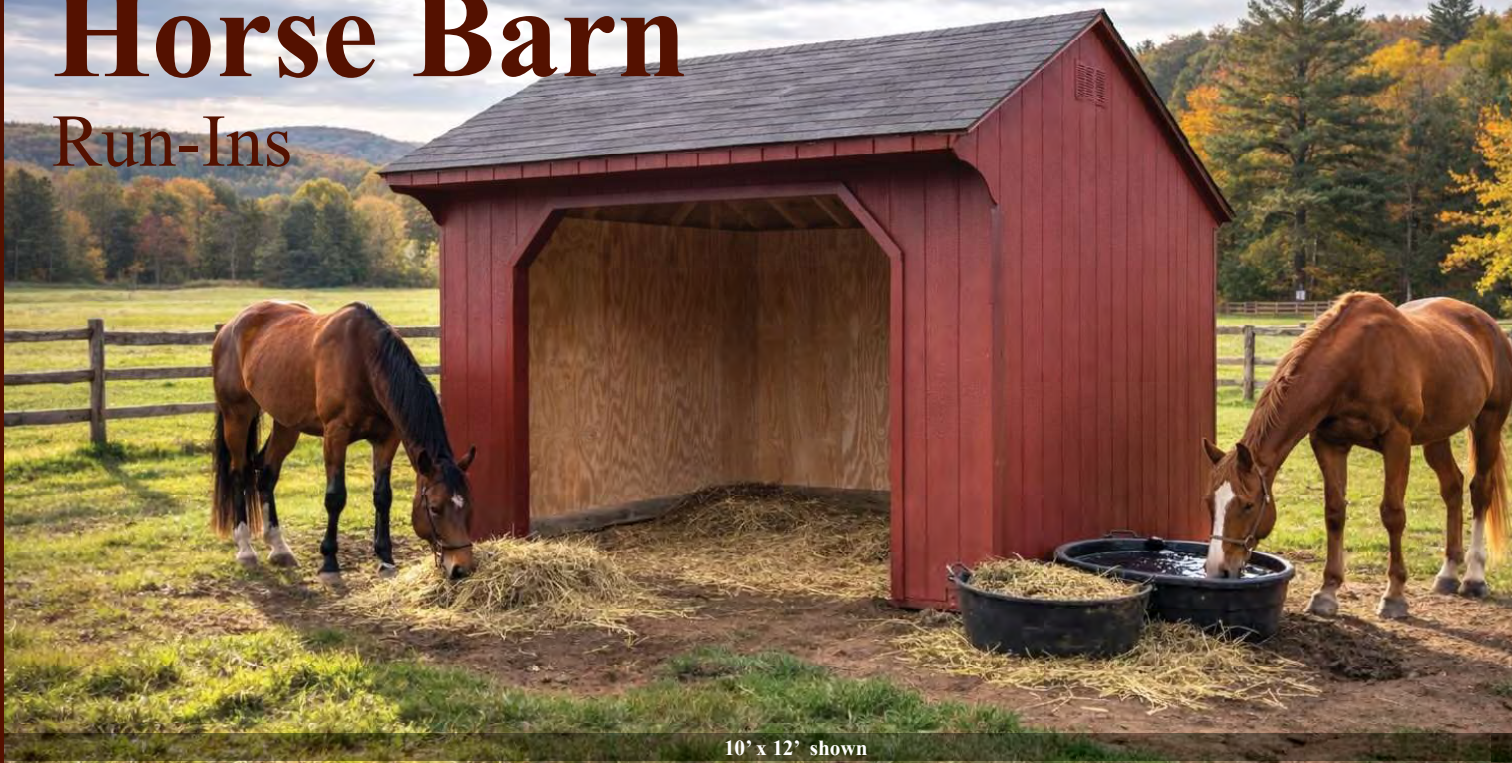

10' x 12' shown



8' x 12' shown

Run-In Barns

Standard Features:

- Cottage Style Roof Line
- LP Engineered Wood Siding
- Architectural Shingles
- No Floor
- Two Gable Vents
- Plywood to Square
- Trim Style
 - Classic = Metal
 - Colonial = Miratec
- Overhang
 - Classic = 3"
 - Colonial = 6"

Run-In	Classic	Colonial
8x10	\$5,169	\$5,257
8x12	\$5,744	\$5,840
8x14	\$6,311	\$6,415
8x16	\$6,953	\$7,069
8x18	\$7,450	\$7,567
8x20	\$7,882	\$8,002
10x10	\$6,168	\$6,274
10x12	\$6,772	\$6,883
10x14	\$7,397	\$7,515
10x16	\$8,118	\$8,243
10x18	\$8,680	\$8,809

Run-In	Classic	Colonial
10x20	\$9,369	\$9,510
10x22	\$10,058	\$10,208
12x12	\$7,299	\$7,414
12x14	\$8,018	\$8,140
12x16	\$8,854	\$8,987
12x18	\$9,547	\$9,685
12x20	\$10,363	\$10,515
12x22	\$11,123	\$11,281
12x24	\$11,898	\$12,069
12x26	\$12,383	\$12,565
12x28	\$13,105	\$13,301

FREE DELIVERY
within 50 miles!

All barns are customizable.

Horse Barn Options



4' Oak Kick Boards
\$10/lin ft



24" x 36" Grill with Window \$435
24" x 36" Grill with Angle Frame \$485
10' x 24" Grill with Angle Frame \$915



Service Door
3' \$212 4' \$220



Dutch Door
3' \$414 4' \$428

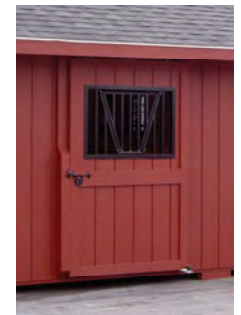

4' Roll Door \$488
(shown with grill window)

Chicken Coop Combination



6' x 12' shown

Combination Chicken Coops



Standard Features:

- Enclosed hen house area
- Fenced in area with gate
- Lift top hatch over nesting boxes
- Two 18" x 23" windows
- Chicken door with ramp
- Access door
- Roosting bar
- Vent with lid
- LP Engineered Wood siding
- Miratec trim
- Architectural shingles
- Pressure treated floor, legs and runners

Delivery
Available

Combination Coop	4' x 8'	6' x 8'	6' x 12'
Base Price	\$3,875	\$4,415	\$5,650
Hen house	4' x 4'	4' x 6'	6' x 6'
Run Area	4' x 4'	4' x 6'	6' x 6'
Nesting boxes	four	four	six
# of Chickens	8 - 12	12 - 15	16 - 20
Epoxy Floor	\$190	\$190	\$315
Metal Roof	\$205	\$280	\$295
Clean Out Lid	\$220	\$220	\$220



4' x 8' shown



6' x 8' shown



4' x 6' shown



4' x 6' with 4' x 5' run shown

Cottage Chicken Coops

Standard Features:

- 4' x 6'
- Six nesting boxes
- Lift top hatch over nesting boxes
- For 12 - 15 chickens
- Two 18" x 23" windows
- Chicken door with ramp
- Access door
- Roosting bar
- Vent with lid
- LP Engineered Wood siding
- Miratec trim
- Architectural shingles
- Pressure treated floor, legs and runners

Cottage Coop	\$3,050
Epoxy Floor	\$200
Metal Roof	\$190
Deluxe Wagon (four wheels with steering handle)	\$885
Clean Out Lid	\$200
4'x5' Chicken Run	\$725
4'x7' Chicken Run	\$925
5'x7' Chicken Run	\$1,025

Delivery Available



4' x 6' with 4' x 7' run shown



4' x 6' shown



4' x 6' shown



3' x 4' shown

Quaker Chicken Coops

Standard Features:

- 3' x 4'
- Four nesting boxes
- Lift top hatch over nesting boxes
- For 4 - 8 chickens
- One 12" x 18" window
- Chicken door with ramp
- Access door
- Roosting bar
- Vent with lid
- LP Engineered Wood siding
- Miratec trim
- Architectural shingles
- Pressure treated floor, legs and runners

Quaker Coop	\$2,425
Epoxy Floor	\$125
Metal Roof	\$115
Wheelbarrow (two wheels and handles)	\$575
Tractor Package (wheelbarrow and run set-up)	\$500
Wagon (four wheels and handle)	\$650
Clean Out Lid	\$200

Delivery
Available



3' x 4' shown



3' x 4' shown



3' x 4' with tractor package shown

Site Selection and Preparation

ACCESSIBILITY:

Choose a spot where we can back up to the short side of the pad with our truck and trailer.



Our 22' truck with a 28' or 38' trailer must be able to back up to the short side of the pad.

Choosing the location for your new shed, barn or gazebo:

- Is the site level, or can it be made level?
- Is the short side of the pad sufficiently accessible for our truck and trailer? "
- Is the ground (driveway and/or lawn) hard enough for us to drive on with a heavy truck, trailer and shed?
- We can NOT drive over ANY type of septic system, mound system, leach field, etc.
- We are not responsible for property damage caused during the delivery process.
- It is recommended that double wide buildings (over 14' wide) have a concrete base.



APPROACH: The ground must be dry and solid and the entire approach must be clear of obstacles.



Above: We need at least 13'6" clearance, and even more space above the pad where the trailer will tilt up to off load the shed. Check for overhead wires, house eaves, branches and other obstacles.



Sides: We need the width of your shed plus one foot on each side. The approach and site must be clear from the road all the way to your site. Check for branches, bushes, fencing, play grounds, etc.



Below: The ground (driveway and/or lawn) must be hard enough for us to drive on with a heavy truck, trailer and shed. We will leave ruts and/or get stuck if it is not. We can not drive over any type of septic system, mound system, leach field, etc.

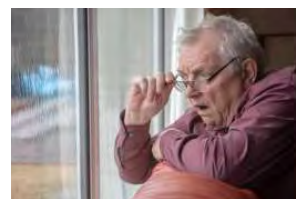

Abutting Property: We can not drive across your neighbor's property without their written permission. Ask us for a liability waiver if needed.

LEVEL SITE: Your shed needs a flat and level pad with enough material to prevent settling.

To create a flat and level base for your new structure use a 3/4" crushed stone or gravel and create a pad that is two feet bigger than the shed on all four sides. It may need to be thicker in some areas than in others for it to be level. Use enough material to prevent settling, we suggest a minimum of 4" to 6", depending on soil type. To ensure your pad is square measure diagonally from corner to corner, the two diagonals should measure the same. To make sure your pad is level, use a transit or a long board with a level to check it in several spots.

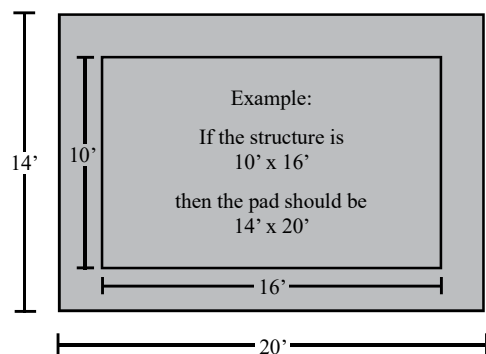

Top View

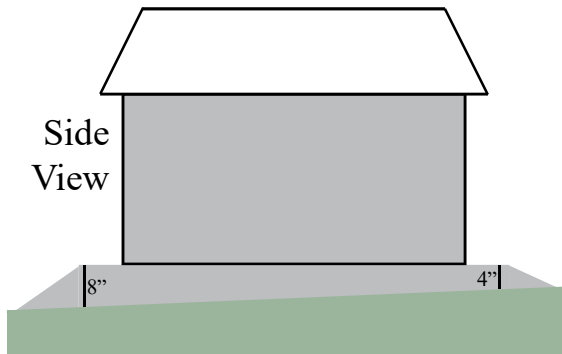

Please Note:

* We do not recommend using cinder blocks to level or support your shed

* If your shed pad is not level then your doors and windows will not function properly

* Livingston Farm's crew is not responsible for fixing shed pads that are not level

Specifications & Delivery

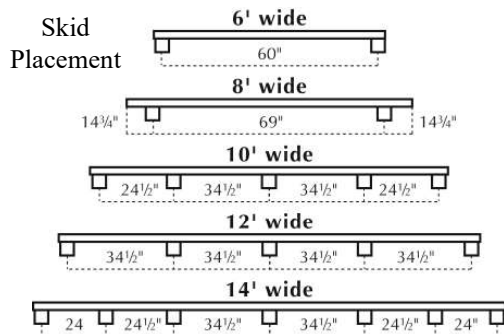
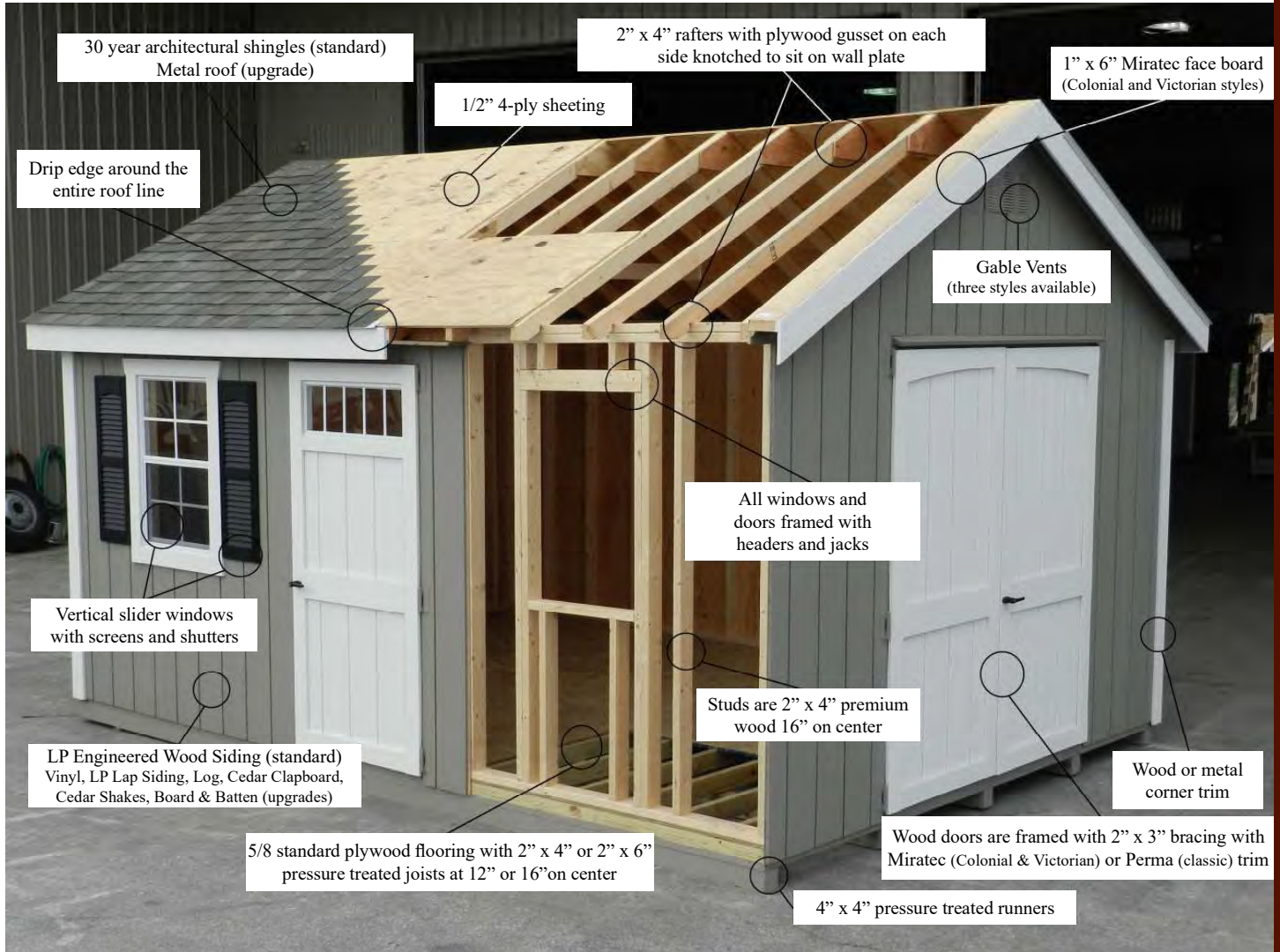

FREE DELIVERY
within 50 miles!

Free delivery within 25 miles for buildings requiring on site assembly.

Our specially designed trailer allows for fast and convenient delivery.



Prepare your own base or let Livingston Farm's expert crew prep it for you!

See page 120 for important delivery details!

Gazebos

Octagon



10' shown



10' shown

Octagon Gazebos

Octagonal Gazebos	Screen Kit	Floor Screen	Vinyl Pane Windows w/ Screens	Pagoda Roof	Add Top Rails	
8'	\$5,182	\$904	\$88	\$3,395	\$1,218	\$185
10'	\$6,819	\$1,168	\$144	\$3,629	\$1,312	\$226
12'	\$8,413	\$1,339	\$175	\$3,843	\$1,464	\$278
14'	\$10,208	\$1,548	\$240	\$4,498	\$1,676	\$316

Standard Features:

- Pressure treated construction
- Flat spindles on rails
- Architectural shingles
- Cupola

FREE DELIVERY
within 50 miles!



12' shown



14' shown



14' shown

Gazebos

Oval



12' x 16' shown

Oval Gazebos

Standard Features:

- Pressure treated construction
- Architectural shingles
- Flat spindles on rails
- Add a standard cupola for \$286

FREE DELIVERY
within 50 miles!

	Oval Gazebos	Screen Kit	Floor Screen	Vinyl Pane Windows w/ Screens	Pagoda Roof	Add Top Rails
8x10	\$6,446	\$1,344	\$98	\$4,822	\$1,352	\$215
8x12	\$7,071	\$1,434	\$116	\$4,972	\$1,414	\$234
10x12	\$7,942	\$1,455	\$148	\$5,037	\$1,486	\$310
10x16	\$9,480	\$1,586	\$193	\$5,518	\$1,669	\$330
10x18	\$10,305	\$1,680	\$215	\$5,616	\$1,731	\$338
12x16	\$10,991	\$1,707	\$225	\$5,742	\$1,746	\$347
12x20	\$13,046	\$1,920	\$277	\$5,956	\$1,900	\$409
12x24	\$14,812	\$2,198	\$331	\$7,228	\$2,040	\$436
14x20	\$15,939	\$2,286	\$319	\$7,902	\$2,237	\$455
14x24	\$18,327	\$2,460	\$378	\$8,488	\$2,418	\$353



12' x 16' shown

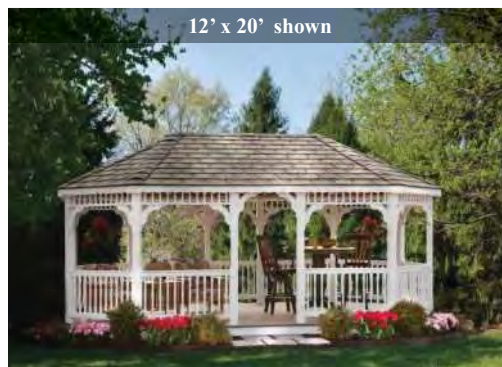

12' x 20' shown



10' x 12' shown

Gazebos

Squares & Rectangles



10' x 14' shown

Square & Rectangular Gazebos

Standard Features:

- Pressure treated construction
- Flat spindles on rails
- Architectural shingles
- Cupola included on squares
- Add a standard cupola to a rectangle for \$305

FREE DELIVERY
within 50 miles!

	Square & Rectangular Gazebos	Screen Kit	Floor Screen	Vinyl Pane Windows w/ Screens	Pagoda Roof	Add Top Rails
8x8	\$5,552	\$1,180	\$80	\$3,986	\$1,246	\$188
8x12	\$7,248	\$1,358	\$130	\$4,302	\$1,348	\$250
8x14	\$7,891	\$1,418	\$148	\$4,475	\$1,408	\$278
10x10	\$7,041	\$1,343	\$125	\$4,188	\$1,374	\$250
10x12	\$8,104	\$1,351	\$148	\$4,688	\$1,432	\$288
10x16	\$9,656	\$1,517	\$198	\$5,088	\$1,615	\$336
12x12	\$8,741	\$1,577	\$175	\$4,998	\$1,546	\$350
12x16	\$11,201	\$1,639	\$228	\$5,255	\$1,625	\$380
12x20	\$13,302	\$1,871	\$285	\$6,772	\$1,862	\$435
12x24	\$15,074	\$2,159	\$335	\$7,316	\$1,968	\$460
14x14	\$12,144	\$2,100	\$270	\$7,007	\$1,863	\$388
14x16	\$13,872	\$2,126	\$284	\$7,075	\$1,911	\$413
14x20	\$16,244	\$2,281	\$328	\$7,954	\$2,150	\$477
14x24	\$18,715	\$2,456	\$390	\$8,824	\$2,343	\$503



10' x 10' shown



8' x 12' shown



12' x 12' shown

Gazebo Options

BENCHES

per section
 8' wide \$95
 10' wide \$108
 12' wide \$128
 14' wide \$141

FINISH COLORS

Cedar Stain add 5%
 Water Sealer add 5%
 Paint add 10%

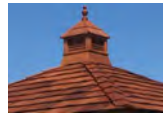

Cedar Stain



White



Beige



Cream



Avocado

GAZEBO ROOF OPTIONS

Cedar Shake Shingles
 L x W x \$12



Bell Roof
 L x W x \$9



Pagoda Roof

Priced per size, shown on pages 28 & 29



ARCHITECTURAL SHINGLES

Standard



Weatherwood



Rustic Cedar



Rustic Evergreen



Rustic Black



Old English Pewter



Rustic Virginia Slate



Rustic Redwood



Rustic Slate



Dual Brown



Aged Redwood



National Blue



METAL ROOF Length x Width x \$6.00

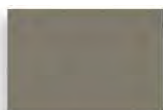

Clay



Black



Red



Blue

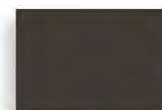

Charcoal



Evergreen

CUPOLAS

STANDARD SERIES

BASE / TOP	18" Oct x 20"h	21" Oct x 25"h
Vinyl / Copper	\$550	\$631
Vinyl / Cedar	\$457	\$526
Treated Pine / Copper	\$517	\$607
Treated Pine / Cedar	\$432	\$503



ESTATE SERIES Featuring a vinyl or cedar base with a copper top.

Size	Villa	Pinnacle
24"Oct x 36"h	\$1,190	\$1,136
30"Oct x 45"h	\$1,529	\$1,398
36"Oct x 51"h	\$1,825	\$1,707
42"Oct x 60"h	\$2,281	\$2,136
48"Oct x 68"h	\$2,700	\$2,499

Size	Salisbury	Kingston
24"Oct x 36"h	\$1,136	\$1,082
30"Oct x 47"h	\$1,439	\$1,319
36"Oct x 52"h	\$1,756	\$1,637
42"Oct x 62"h	\$2,208	\$2,044
48"Oct x 70"h	\$2,615	\$2,426



Pergolas



10' x 14' shown

Pergolas

Standard Features:

- Pressure treated construction
- Pressure treated floor
- Double 2" x 8" header on two sides
- Double 2" x 6" return beams on two sides
- Corner braces
- 2" x 6" runners with decorative ends
- Stainless steel mounting brackets
- 5" x 5" posts with 16" skirt
- 2" x 2" top runners

FREE DELIVERY
within 50 miles!

Assembled with a Floor	
8x8	\$4,574
8x10	\$5,137
8x12	\$5,829
8x14	\$6,520
8x16	\$7,207
10x10	\$5,921
10x12	\$6,756
10x14	\$7,582
10x16	\$8,438
10x20	\$10,462
10x24	\$12,097

Assembled with a Floor	
12x12	\$7,659
12x14	\$8,585
12x16	\$9,571
12x20	\$11,839
12x24	\$13,752
12x28	\$15,217
14x14	\$9,610
14x16	\$10,672
14x20	\$13,298
14x24	\$15,322
14x28	\$17,530

For cedar stain or water sealer add 10%

For cedar construction add 15%

For vinyl construction add 20%



10' x 12' shown



12' x 12' shown

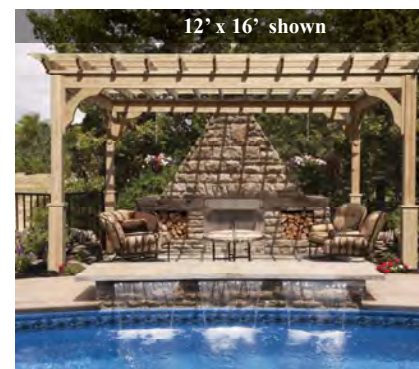

12' x 16' shown

Pavilions



12' x 12' shown

Pavilions with a Floor

Floorless Pavilion	Hip Roof 6:12 pitch	Aframe 6:12 pitch
8x8	\$6,098	\$6,003
8x10	\$6,747	\$6,652
8x12	\$7,498	\$7,403
8x14	\$8,337	\$8,219
10x10	\$7,829	\$7,710
10x12	\$8,741	\$8,622
10x14	\$9,738	\$9,595
10x16	\$10,725	\$10,583
10x18	\$11,684	\$11,518
12x12	\$9,849	\$9,706
12x14	\$10,997	\$10,830
12x16	\$12,474	\$12,307
12x18	\$13,613	\$13,423
12x20	\$15,602	\$15,388
12x24	\$17,836	\$17,598

Standard Features:

- Pressure treated construction
- Architectural shingles
- 5" x 5" posts (6"x6" posts on vinyl)
- 16" post base
- Pressure treated pine floor and runners
- Aframe style roof has open gables

Delivered completely assembled, first 50 miles FREE!

For cedar stain add \$5/sq ft
 For cedar construction add 25%
 For vinyl construction add 25%
 Upgrade to metal roof add \$6/sq ft

Floorless Pavilions

Standard Features:

- Pressure treated construction
- Architectural shingles
- 5" x 5" posts (6"x6" posts on vinyl)
- 16" post base
- No floor
- Aframe style roof has open gables

Delivery and on site Assembly, first 25 miles FREE!

Floorless Pavilion	Hip Roof 6:12 pitch	Aframe 6:12 pitch	Aframe 9:12 pitch
8x10	\$13,306	\$13,163	\$13,772
8x12	\$13,947	\$13,804	\$14,478
10x12	\$14,877	\$14,687	\$15,603
10x14	\$15,729	\$15,539	\$16,679
10x16	\$16,570	\$16,380	\$17,695
12x12	\$15,836	\$15,551	\$16,710
12x16	\$18,254	\$17,969	\$19,556
12x20	\$21,488	\$21,203	\$23,221
12x24	\$23,880	\$23,595	\$25,996
14x14	\$18,595	\$18,215	\$19,814
14x20	\$23,741	\$23,361	\$25,734
14x24	\$26,427	\$26,047	\$28,834
14x28	\$29,096	\$28,716	\$31,926
16x20	\$25,661	\$25,186	\$27,911
16x24	\$28,525	\$28,050	\$31,230
16x28	\$31,594	\$31,119	\$34,742
20x20	\$29,785	\$29,215	\$32,549
20x24	\$33,264	\$32,694	\$36,639
20x28	\$35,772	\$35,202	\$39,660



12' x 16' shown



8' x 12' shown



12' x 16' shown

Contemporary Playhouse

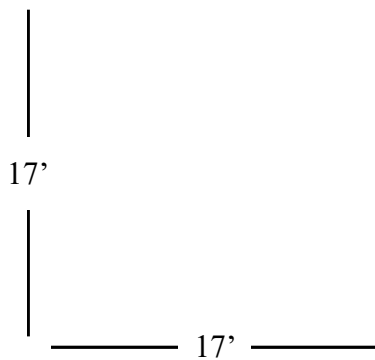

\$3,020 as shown

- 5' x 6' Playhouse
- 6' Mountain climb
- Aframe with beam
- Two sling swings
- Entrance ladder
- 5' x 6' Sandbox
- Wooden glider
- Scoop slide

Country Cabin

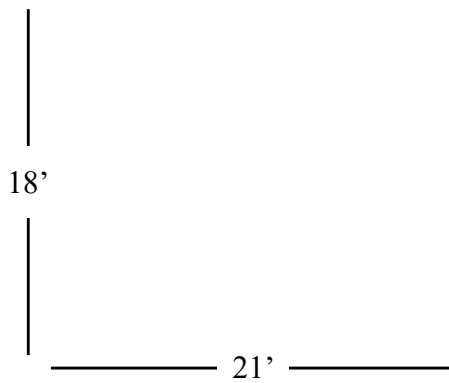

\$4,290 as shown

- 6' x 7' Playhouse
- Three working windows
- 6' Mountain climb
- 6' x 7' Sandbox
- Aframes with beam
- Two sling swings
- Wooden glider
- Trapeze
- Entrance ladder
- Scoop slide

Slide Tower Deluxe



\$1,980 as shown

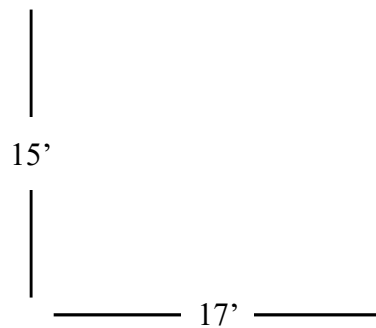

- Two aframes with beam
- 6' Mountain climb
- Plastic bucket swing
- Two sling swings
- Wooden glider
- Entrance ladder
- Scoop slide
- Hand rails
- Platform

Cabinette

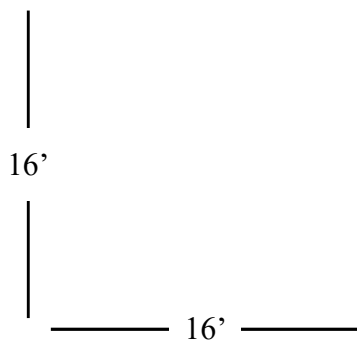

\$2,680 as shown

- 4' x 6' Playhouse
- Two working windows
- 4' x 6' Sandbox
- Aframe with beam
- Two sling swings
- Wooden glider
- Entrance ladder
- Scoop slide

Play Set Options

Fun add-ons for any of our play sets!

Telescope
\$48



Steering Wheel
\$48



4' x 6' \$200

Sandbox Cover
5' x 6' \$210

6' x 7' \$220



Commitment to Safety

A level site, along with several feet of clearance around the playset is recommended for maximum safety. The area beneath your play set should be covered with a soft material such as mulch or pea stone. Children should always be supervised while playing on a play set.

Commitment to Quality

Our wooden play structures are crafted using Wolmanized Residential Outdoor Wood which has earned the Good Housekeeping Seal. The components are constructed from premium grade southern yellow pine that is pressure treated so it will last for decades. Wolmanized outdoor wood is environmentally responsible as a renewable resource. We recommend that all wooden parts of the play set be treated yearly with water sealer to protect its smooth finish and natural beauty.

Commitment to Improving

Livingston Farm Landscape, LLC reserves the right to make product and design modifications to improve the safety and/or value of our play sets.



Poly Fire Pits



38" Round Fire Pit
Propane tank not included
#C711SP \$1,350
#C711CP \$1,400
#C711RP \$1,450



34" Square Fire Pit
Propane tank not included
#C811SP \$1,675
#C811CP \$1,725
#C811RP \$1,800



The Fan Back Collection



5' Fan Back Console Glider Bench
 #C342SP \$941
 #C342CP \$999
 #C342RP \$1,073



4' Fan Back Glider Bench
 #C340SP \$711
 #C340CP \$755
 #C340RP \$811



Fan Back Single Glider
 #C114SP \$485
 #C114CP \$514
 #C114RP \$555



Fan Back Swivel Glider
 #C119SP \$583
 #C119CP \$616
 #C119RP \$665



5' Fan Back Swing with Console
 #C352SP \$665
 #C352CP \$707
 #C352RP \$760



4' Fan Back Swing
 #C341SP \$497
 #C341CP \$526
 #C341RP \$569



Fan Back Settee
 #C202SP \$652
 #C202CP \$692
 #C202RP \$746

Items ending in: SP = Standard Poly Color / CP = Custom Poly Color / RP = Rustic Poly Colors

Colors are shown on pages 142 & 143



Fan Back Rocker
 #C365SP \$373
 #C365CP \$396
 #C365RP \$427



Classic Porch Rocker
 #V478SP \$305
 #V478CP \$330
 #V478RP \$350



Ottoman
 for Fan Back Folding Chair
 #V107SP \$107
 #V107CP \$115
 #V107RP \$122



Fan Back Folding Chair
 #V104SP \$295
 #V104CP \$314
 #V104RP \$330



Deluxe Fan Back Folding Chair with built in ottoman
 #V105SP \$396
 #V105CP \$427
 #V105RP \$450



Cup Holder
 For items beginning with C
 #C81SP \$32
 #C81CP \$34
 #C81RP \$38



Cup Holder
 For items beginning with V
 #V121SP \$20
 #V121CP \$22
 #V121RP \$24



Rectangular Two Tier End Table
 24"l x 18"w x 20"h
 #V472SP \$155
 #V472CP \$166
 #V472RP \$171



Round Two Tier Side Table
 22"d x 20"h
 #V471SP \$158
 #V471CP \$171
 #V471RP \$180



Conversation Table
 44"d x 20"h
 #V144SP \$493
 #V144CP \$528
 #V144RP \$555

Items ending in: SP = Standard Poly Color / CP = Custom Poly Color / RP = Rustic Poly Colors

Colors are shown on pages 142 & 143

The Roll Back Collection



Roll Back Chair
 #V254SP \$365
 #V254RP \$396
 #V254RP \$419



Roll Back Glider Chair
 #V231SP \$485
 #V231CP \$528
 #V231RP \$558



Roll Back Swivel Glider
 #V233SP \$496
 #V233CP \$539
 #V233RP \$569



Glider Ottoman
 #V234SP \$236
 #V234CP \$254
 #V234RP \$267



4' Roll Back Glider
 V235SP \$600
 V235CP \$649
 V235RP \$679



5' Roll Back Glider
 V236SP \$675
 V236CP \$733
 V236RP \$770



5' Roll Back Console Glider
 V245SP \$784
 V245CP \$861
 V245RP \$909



Roll Back Swing
 4' V237SP \$411
 4' V237CP \$447
 4' V237RP \$467



Roll Back Swing
 5' V238SP \$485
 5' V238CP \$531
 5' V238RP \$558

Items ending in: SP = Standard Poly Color / CP = Custom Poly Color / RP = Rustic Poly Colors

Colors are shown on pages 142 & 143

The West Chester Collection



West Chester Bench

4' #C420SP \$431 5' #C520SP \$549
 4' #C420CP \$457 5' #C520CP \$583
 4' #C420RP \$490 5' #C520RP \$625



West Chester Glider Bench

4' #C400SP \$619 5' #C500SP \$720
 4' #C400CP \$657 5' #C500CP \$760
 4' #C400RP \$708 5' #C500RP \$820



West Chester Swing

4' #C410SP \$422 5' #C510SP \$514
 4' #C410CP \$448 5' #C510CP \$546
 4' #C410RP \$480 5' #C510RP \$589



Chaise Lounge

#C801SP \$497
 #C801CP \$528
 #C801RP \$569



Chaise Lounge with Arms

#C801ASP \$563
 #C801ACP \$597
 #C801ARP \$640



Round Side Table

22"d x 20"h
 #C76SP \$177
 #C76CP \$188
 #C76RP \$202

Items ending in: SP = Standard Poly Color / CP = Custom Poly Color / RP = Rustic Poly Colors

Colors are shown on pages 142 & 143



Round English Garden & Bistro Dining Tables
30" high

30" diameter
#C730DSP \$442
#C730DCP \$467
#C730DRP \$502



42" diameter
#C742DSP \$589
#C742DCP \$622
#C742DRP \$672



48" diameter
#C748DSP \$714
#C748DCP \$758
#C748DRP \$814



60" diameter
#C760DSP \$969
#C760DCP \$1,029
#C760DRP \$1,104

English Garden Coffee Table
39" long x 17" wide x 18" high
#C970SP \$320
#C970CP \$340
#C970RP \$368



Square English Garden & Bistro Dining Tables
43" wide x 30" high

43" long
#C843DSP \$631
#C843DCP \$670
#C843DRP \$724



72" long
#C872DSP \$926
#C872DCP \$983
#C872DRP \$1,055

96" long
#C896DSP \$1,128
#C896DCP \$1,191
#C896DRP \$1,288





English Garden Swivel Chair
 #C228DSP \$465
 #C228DCP \$493
 #C228DRP \$531



English Garden Chair With Arms
 #C221DSP \$339
 #C221DCP \$359
 #C221DRP \$387



English Garden Chair
 #C220DSP \$314
 #C220DCP \$334
 #C220DRP \$360



English Garden Bench
 #C940SP \$459
 #C940CP \$488
 #C940RP \$526



Bistro Swivel Chair
 #C328DSP \$476
 #C328DCP \$505
 #C328DRP \$545



Bistro Chair
 #C321DSP \$336
 #C321DCP \$356
 #C321DRP \$383

Dining Benches
 15" wide x 18" high

42" long
 #C164DSP \$334
 #C164DCP \$354
 #C164DRP \$382



72" long
 #C166DSP \$430
 #C166DCP \$456
 #C166DRP \$488



96" long
 #C168DSP \$503
 #C168DCP \$534
 #C168DRP \$577



The Balcony & Pub Collections



44" Pub Table
44" diameter x 39" high
#V344SP \$500
#V344CP \$539
#V344RP \$565



22" Pub Table
22" diameter x 34" high
#V322SP \$229
#V322CP \$251
#V322RP \$264



Roll Back Pub Chair
26" high seat
#V327SP \$382
#V327CP \$419
#V327RP \$442



Roll Back Pub Swivel Chair
26" high seat
#V328SP \$457
#V328CP \$500
#V328RP \$523



Rectangular Balcony Table
43" wide x 36" high
43" long 72" long 96" long
#C843CSP \$678 #C872CSP \$996 #C896CSP \$1,214
#C843CCP \$719 #C872CCP \$1,052 #C896CCP \$1,289
#C843CRP \$772 #C872CRP \$1,135 #C896CRP \$1,375



Fan Back Balcony Settee
24" high seat
#C322SP \$811
#C322CP \$861
#C322RP \$924



Fan Back Balcony Chair
24" high seat
#C321CSP \$387
#C321CCP \$410
#C321CRP \$442



Fan Back Balcony Swivel Chair
24" high seat
#C328CSP \$483
#C328CCP \$513
#C328CRP \$554

Items ending in: SP = Standard Poly Color / CP = Custom Poly Color / RP = Rustic Poly Colors

Colors are shown on pages 142 & 143

Picnic & Patio Tables



Poly Rectangle Picnic Table with attached benches
 72" w x 60.5" d x 30" h
 72" x 33" Tabletop
 #W301PSP \$1,115
 #W301RP \$1,240



Poly Rectangle Picnic Table with attached benches
 96" w x 60.5" d x 30" h
 96" x 33" tabletop
 #W302PSP \$1,455
 #W302PRP \$1,585



Poly Octagon Picnic Table with attached benches
 79" w x 79" d x 29.5" h
 52" diameter tabletop
 #W303PSP \$1,625
 #W303PRP \$1,790



Poly Bench
 42" long #W601PSP \$264
 42" long #W601PRP \$293
 66" long #W603PSP \$347
 66" long #W603PRP \$387



Poly Patio Table
 72" x 33" #W202PSP \$658
 72" x 33" #W202PRP \$736
 72" x 44" #W206PSP \$797
 72" x 44" #W206PRP \$891



Poly Bench with Back
 42" #W501PSP \$390
 42" #W501PRP \$434
 66" #W503PSP \$482
 66" #W503PRP \$537

Items ending in: SP = Standard Poly Color / CP = Custom Poly Color / RP = Rustic Poly Colors

Colors are shown on pages 142 & 143

Poly

How to interpret our furniture product codes and pricing:

First letter: — **V104SP** — **Last two letters:**
 tells you which group of colors to reference: V, C or W
 tells you which type of color it is:
 SP = Standard Poly Color
 CP = Custom Poly Color
 RP = Rustic Poly Color

Middle digits:
 tells us which product it is





Poly color choices for items beginning with

C

-  Sea Foam
-  Sea Glass
-  Purple
-  Pink
-  Orange
-  Yellow

Custom Colors

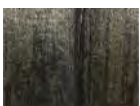
-  Rustic Gray
-  Rustic Nutmeg
-  Rustic Caramel
-  Rustic Barnwood

Rustic Colors

-  White
-  Ivory
-  Gray
-  Dark Gray
-  Weatherwood
-  Cedar
-  Brown
-  Black
-  Green
-  Lime Green
-  Turquoise
-  Ocean Blue
-  Blue
-  Patriot Blue
-  Burgundy

Standard Colors

Color Options

Colors shown are representational and cannot be guaranteed to match.

Suggested Two-Tone Color Combos

Choose any color combination, not limited to those shown



Poly color choices for items beginning with W

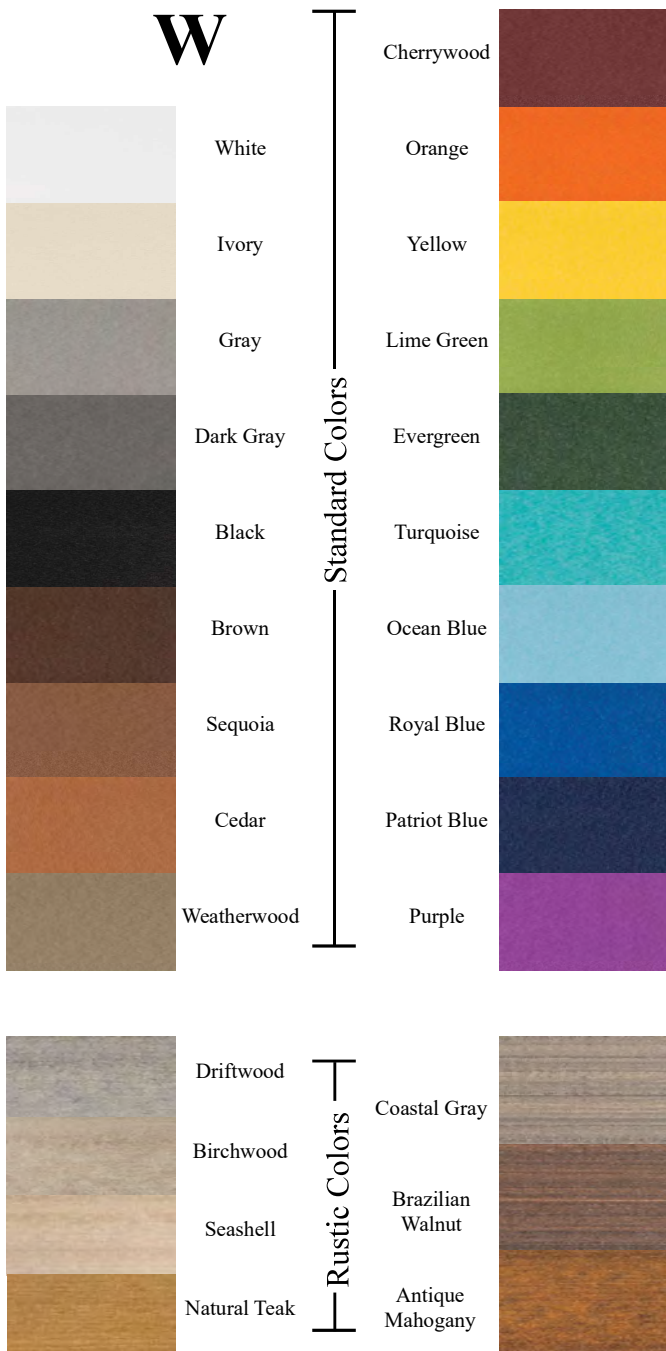

Poly color choices for items beginning with V





40 South 116 Road
Bristol, Vermont 05443
info@livingstonfarm.com

802-453-2226
LivingstonFarm.com
GreenMountainVeneer.com